

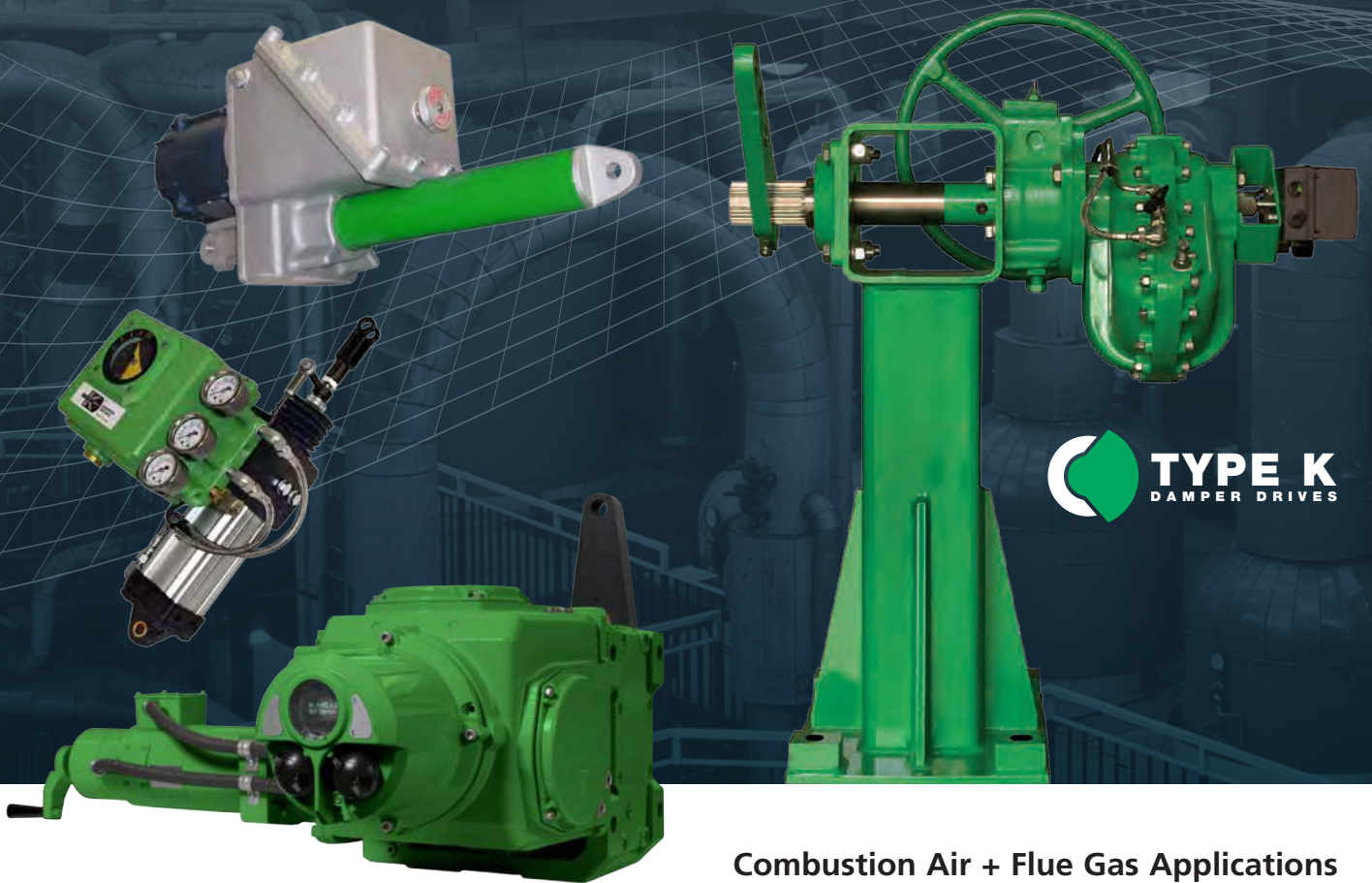

Rotary + Linear Damper Drives

Pneumatic and Electric



Combustion Air + Flue Gas Applications

Redefining Flow Control



Contents

Section	Page
Introduction	3
Controlling Boiler Combustion Air & Flue Gas	4
Rotary Damper Drive Range	6
TYPE K Retrofit Technology	8
PM & DM Series	10
SM-6000 S2 Series	12
SM-1700/5000 Series	14
VA Series	16
AH Series	16
IQ3 Series	17
CVQ Series	18
Linear Damper Drive Range	20
TYPE K Cylinder Features	22
CT Series	23
JR Series	24
LX Series	25
LA-2000 Series	26
CVL Series	28
Accessories	29
Rotork Site Services	30



Stack Damper at Refinery



Rotork is the global market leader in valve automation and flow control. Our products and services are helping organizations around the world to improve efficiency, assure safety and protect the environment.

We strive always for technical excellence, innovation and the highest quality standards in everything we do. As a result, our people and products remain at the forefront of flow control technology.

Uncompromising reliability is a feature of our entire product range, from our flagship electric actuator range through to our pneumatic, hydraulic and electro-hydraulic actuators, as well as instruments, gearboxes and valve accessories.

Rotork is committed to providing first class support to each client throughout the whole life of their plant, from initial site surveys to installation, maintenance, audits and repair. From our network of national and international offices, our engineers work around the clock to maintain our position of trust.

Rotork. Redefining flow control.

Introduction

Rotork offers a full-line of electric and pneumatic damper control solutions for the isolation and control of combustion air and flue gas. Our products improve the efficiency and reliability of large and small boilers, furnaces and process heaters and other demanding processes worldwide.

Combustion air and flue gas damper drives fill a critical role requiring safety, accuracy and reliability above all else. Rotork provides an extensive range of rotary and linear damper drives with over 50 years of expertise in the combustion industry. Rotork is the proven solution for your combustion needs with thousands of successful damper drive installations worldwide.

Rotork damper drives will maximize combustion efficiency, minimize emissions and reduce installation costs.

Rotork's broad damper drive line delivers quality, power and performance to a wide range of industries. They excel in applications where precise control and speed increases the BTU/Fuel ratio and increases the MW/Fuel ratio.

Question: What is the result of a better burn?

Answer

Reduced emissions, lower fuel consumption and improved boiler draft control.

How?

- High speed continuous modulation of ID/FD fan and inlet guide vanes
- Improved modulation and control of secondary air dampers
- Improved automation and burner management
- Quick response to plant demand
- Improved reliability in high temperature environments
- Precise damper and burner positioning
- Simple commissioning and diagnostics
- Low running costs, virtually maintenance free
- Pneumatic, analog and bus network communications



TYPE K PM Series on Primary Air Fan Inlet Damper

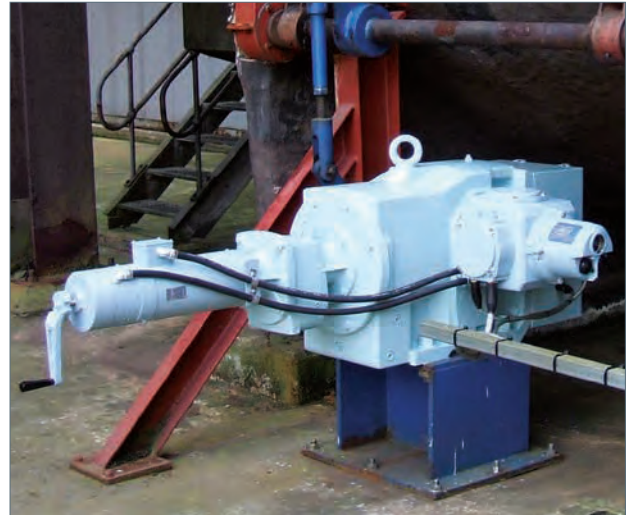

SM-6000 Series on Induced Air Fan Damper



TYPE K DM Series on Windbox application

Controlling Boiler Combustion Air + Flue Gas

Combustion Air & Flue Gas Circuit Typical T-Fired 500 MW Boiler - 158 Damper Drives

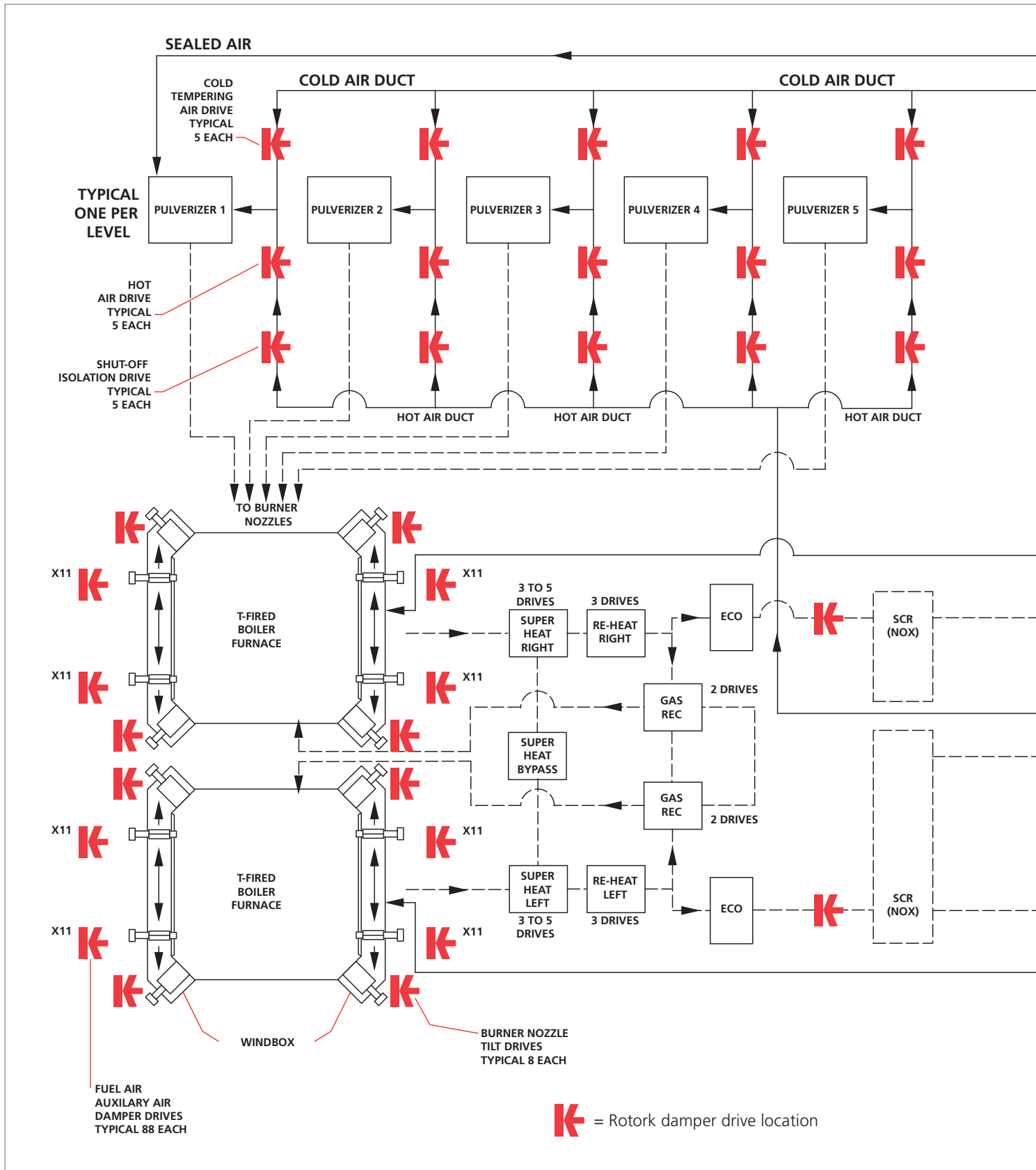

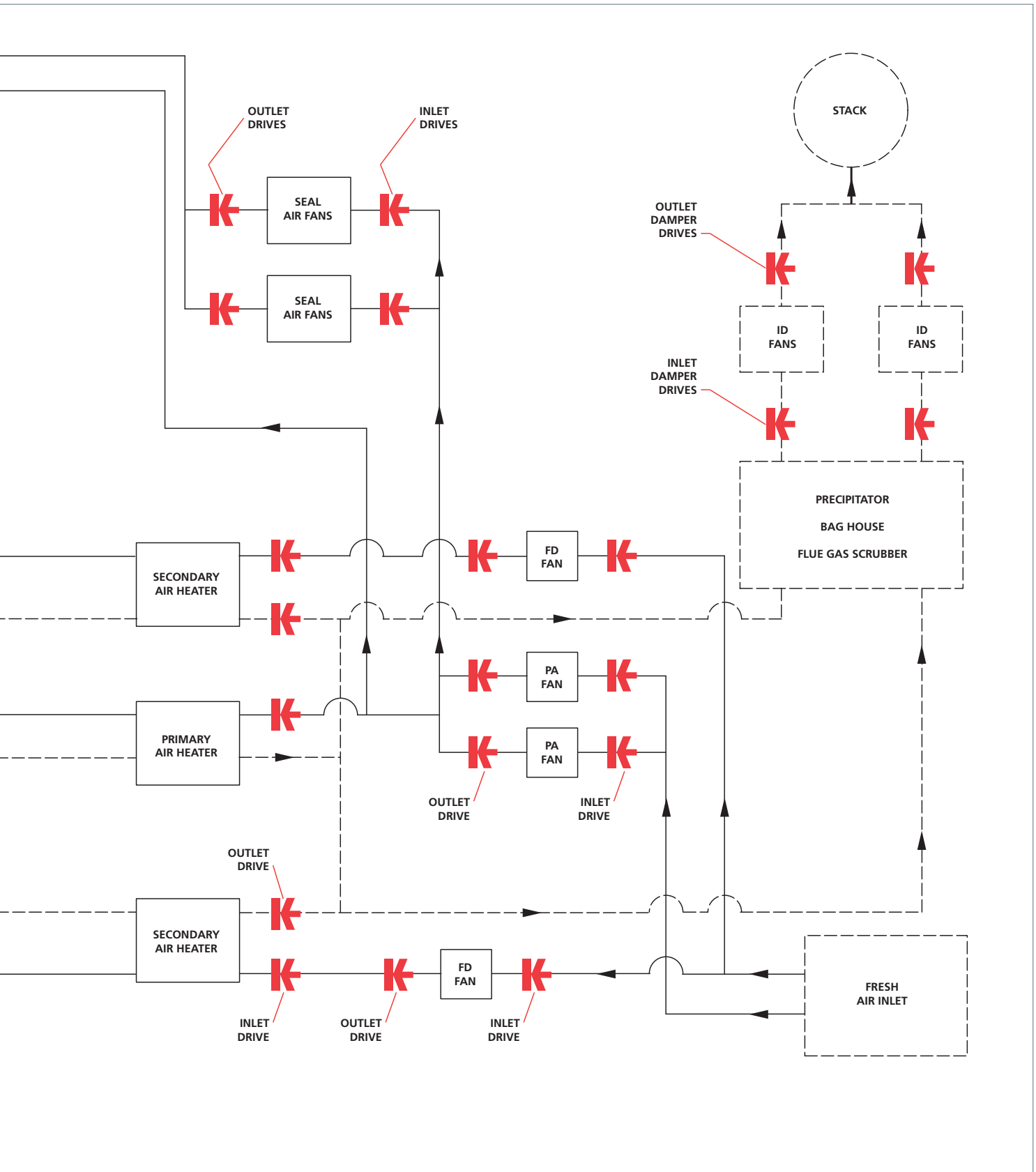

Rotary Damper Drive Range

The following pages contain details on performance and specification for the Rotork range of rotary damper drive actuators.

Please use the following contents table to help access the information you require.

Rotary Damper Drive Range	p7
TYPE K Retrofit Technology	p8
PM & DM Series - Pneumatic	p10
SM-6000 S2 - Electric	p12
SM-1700/5000 Series Rotary Drive - Electric	p14
VA Series (Valve Automation) Rotary Actuator - Pneumatic	p16
AH Series (Ash Hopper) Rotary Actuator - Pneumatic	p16
CVQ Series - Electric	p17
IQ3 Series Rotary and Multi-turn Actuator - Electric	p18



Rotary Damper Drive Range

Rotary Damper Drive Range							
Series	Number of Models	Torque lbf.ft (Nm)	Rotation	Starts/Hour	Power Supply	Warranty	Key Features
PM Series Pneumatic	 Seven (7) Models	32-13,500 (43-18,225)	30-100 degrees rotation	Unlimited / Continuous Duty	40-150 psi supply air	3-Year Warranty	<ul style="list-style-type: none"> Direct 'Drop-In' design matches existing floor-mount drive Re-use existing link rod and clevis Highly accurate and responsive Open-frame design for easy access Pedestal Mount drive
DM Series Pneumatic							
	Seven (7) Models	32-13,500 (43-18,225)	30-100 degrees rotation	Unlimited / Continuous Duty	40-150 psi supply air	3-Year Warranty	<ul style="list-style-type: none"> Mounts directly to boiler wall or damper frame "No Play" connection to damper shaft No side-load on damper shaft (direct drive) Highly accurate and responsive Simple, maintenance-free operation
SM-6000 Series Electric		370-26,000 (502-35,256)	90-313 degrees rotation	Unlimited / Continuous Duty	AC 1-Phase or 3-Phase	2-Year Warranty	<ul style="list-style-type: none"> Unrestricted modulating capability Non-intrusive set-up High-temperature remote-mount electronic option for +225 °F (113 °C) ambient environment Fast operating speeds
SM-1700/5000 Series Electric							
	Five (5) Models	50-12,500 (67-16,950)	0-180 degrees rotation	2,000	AC 1 or 3-Phase or DC supply	2-Year Warranty	<ul style="list-style-type: none"> Foot-, Face- or Side-mount design Variety of levers to match existing Self-locking / no backlash Wide temperature range Scotch-Yoke output torque increases at ends of travel (SM-5000 only)
AH Series Pneumatic		68-1,500 (91-2,025)	30-100 degrees rotation	Unlimited / Continuous Duty	40-150 psi supply air	3-Year Warranty	<ul style="list-style-type: none"> Replace high-maintenance cylinders Extreme high-cycle design Rated for 2-million strokes Totally-enclosed and protected from coal dust and corrosives Ash hopper drive
VA Series Pneumatic							
	Seven (7) Models	32-13,500 (43-18,225)	60-100 degrees rotation	Unlimited / Continuous Duty	40-150 psi supply air	3-Year Warranty	<ul style="list-style-type: none"> Automate butterfly, ball and plug valves Simple, one-moving part design Retrofit linkage available with actuator Complete range of Open / Close and modulating controls Quarter-turn valve automation
CVQ Series Electric		480-2,400 (54.2-271)	0.1-4.5 (2.5-114)	Unlimited / Continuous Duty	AC 1-Phase, 110/240	2-Year Warranty	<ul style="list-style-type: none"> Replace spring & diaphragm actuators Highly accurate with precise control Bluetooth® wireless communication for easy set-up and adjustment Eliminates air consumption
IQ Series Electric							
	Numerous Combinations	100-50,000 (136-67,790)	60-100 degrees rotation	1,200	AC 1 or 3-Phase or DC supply	2-Year Warranty	<ul style="list-style-type: none"> High-reliability solid-state controls Remote setting tool with secured Bluetooth connection Optimized for preventative maintenance Data-logger for comprehensive data capture and analysis Quarter-turn and multi-turn operation

TYPE K Retrofit Technology

The DROP-IN-PLACE solution precisely fits into the application with no field modifications.

Simple, Easy Installation

Our unique Drop-In-Place retrofit concept is focused on providing the end-user with a high-performance drive that can be installed without any field engineering or modification using basic hand tools in a few hours. Existing connecting rods and linkages are reused without modification. Our retrofit drives fit directly on the existing mounting pad using existing hardware.

Improved Damper Operation

Because of our higher operating pressures we can frequently offer more operating torque (within the existing footprint) to compensate for poorly performing older dampers.

High Torque / High Speed

We offer the highest operating torques available, up to 20,800 lbf.ft on pneumatically operated drives and up to 26,000 lbf.ft on electric operated drives with stroking speeds as low as 2 to 3 sec full scale.

Safety & Serviceability

Our design capabilities allow us to frequently offer new solutions permitting drives to be located in more convenient, easier and safer to service locations.



Retrofit Drive

With a TYPE K retrofit drive:

- The drive shaft and drive lever are in the exact same place relative to the floor mounting bolt holes
- The base and mounting holes will match the existing drives
- The lever will be dimensionally identical to the existing lever and will rotate through the same arc
- No costly field design & fabrication



Before Retrofit



After Retrofit

Rotary Damper Drive Range

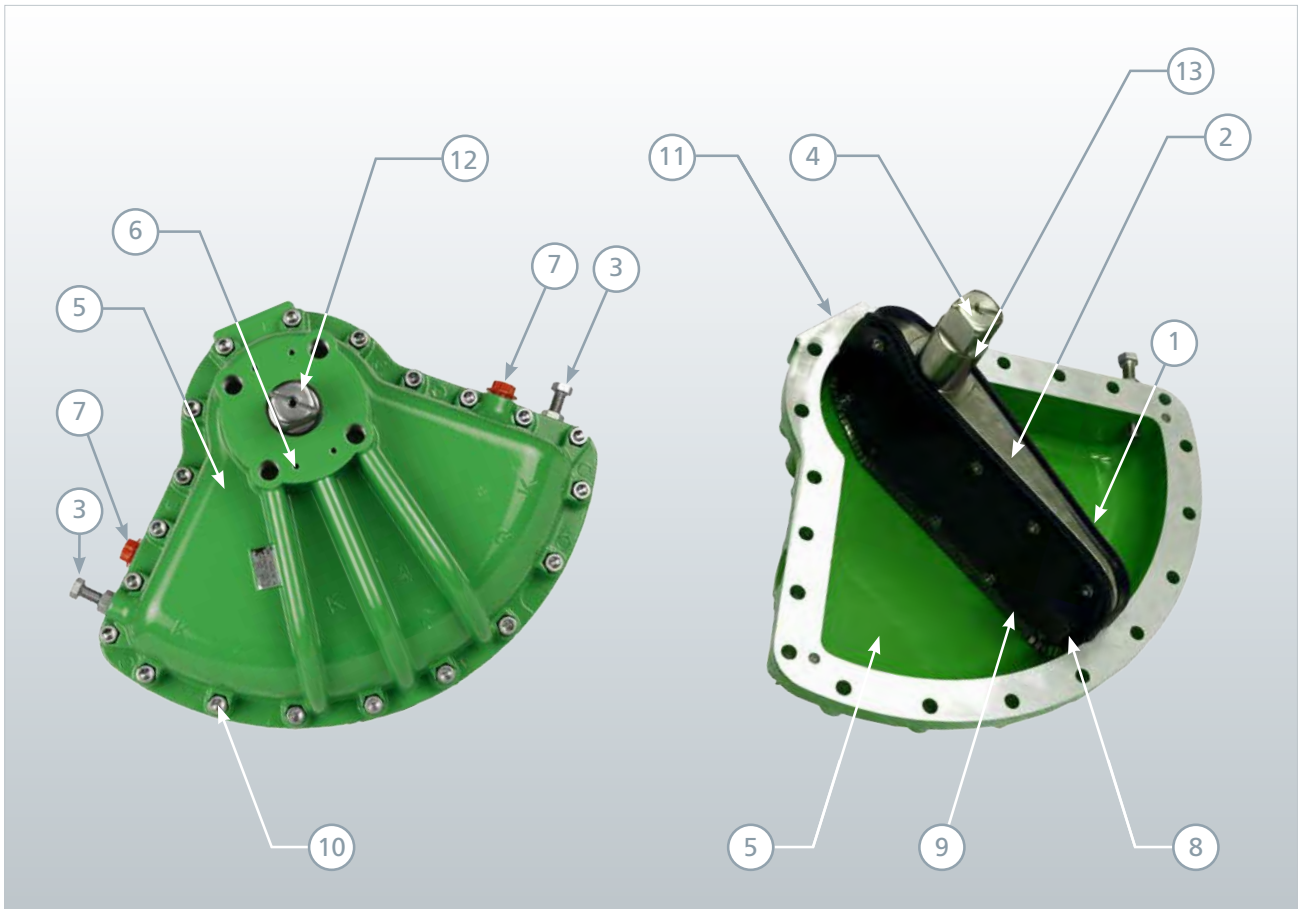

1 Dual Opposed Lip Seals

Provides effective, air-assisted seal for low-friction and long, maintenance-free life.

2 Integral Vane / Shaft Casting

Cast as a single piece; only one moving part. Eliminates all “slop”, hysteresis or lost motion.

3 Bi-Directional Travel Stops

80° to 100° standard adjustments, stainless steel, extended travel stops available. Reduced travel as low as 30° rotation available.

4 Alloy Steel Drive Shaft

High tensile output shafts for strength and durability, ENP finish for corrosion-resistance.

5 Corrosion-Resistant Finish

Durable TGIC-Polyester Epoxy powder-coat finish, inside and out.

6 Integral Namur Accessory Mount

Meets VDI/VE 3485 accessory mount standards for positioners, limit switches and indicators.

7 Large Air Inlet Port for Fast Operation

Provides for high-cycle speed of operation with no restrictions.

8 Steel Side-Plate Seal Retainer

Provides the strength to assure accurate Open and Close stop positions.

9 Stainless Steel Seal Expanders

Ensures long-term lip seal-to-case contact. Excellent in both high-cycle and low-cycle applications.

10 Stainless Steel Bolting Hardware

For long-term corrosion resistance.

11 Integral Namur Manifold

For direct-mount solenoid valve, eliminates fittings and tubing.

12 Wrench Manual Override and Vane Position Indicator

13 No Shaft Seal Required

Vane lipseals isolate output shafts from supply air.

PM & DM Series - Pneumatic

Rotork TYPE K rotary pneumatic damper drives are offered in two basic configurations; the PM Series (Pedestal Mount) and the DM Series (Direct Mount). The Rotork TYPE K PM and DM Series provide accurate quarter-turn control to dampers in combustion air and flue gas applications. They offer modulating control, isolation open/close control and bus network control to fit your operating needs.

The heart of the Rotork TYPE K rotary pneumatic drive is the **HIGH-PERFORMANCE** rotary vane actuator. The totally-enclosed design eliminates internal gears, levers and crank arms where hysteresis is created, leaving an output that has no “lost motion”, “slop” or “backlash”. The result is the most accurate and repeatable pneumatic damper drive available to the industry.

The PM Series is designed to provide **DROP-IN-PLACE** retrofit replacing most any old or current electric or pneumatic damper drive. Installation is usually completed in a short time with simple hand tools.

The DM Series is available with multiple linkage designs to provide direct-mount installation to the boiler wall or damper frame and will couple directly to the damper input drive shaft. All mounting parts included for retrofit applications when replacing existing pneumatic or electric damper drives. Installation is usually completed in a short time with simple hand tools.

Features:

- Improved damper operation – higher torque output with same footprint
- 100% duty cycle, continuous modulating service rating of 3,600 starts / hour without overheating
- High-torque / high-speed – up to 20,800 lbf.ft with stroke speed as low as 3 seconds full scale
- Easily serviced with “open frame” design
- Excellent in harsh, high-temperature environments
- Virtually zero air bleed in resting state – reduces air consumption
- ‘Drop-In-Place’ retrofit eliminates field engineering, speeds up installation



PM Series

Industries

- Electric Utilities
- Refineries (Process Heaters)
- Fluidized Bed Boilers
- Co-Generation
- Pulp & Paper
- Steel, Aluminum and other metals
- Chemical & Petrochemical
- Cement & Lime
- Glass Manufacturing
- Water & Wastewater
- Food & Beverage
- Industrial Power Houses

Applications

- | | |
|-----------------------------------|--|
| Forced Draft (FD) Fan | Air Heater Outlet |
| Induced Draft (ID) Fan | Air Heater Bypass |
| Primary Air (PA) Fan | Superheat Pass Dampers |
| Gas Recirculating Fan | Reheat Pass Dampers |
| Booster Fan | Main Pass Dampers |
| Seal Air Fan | Gas Recirc Tempering |
| CE Windbox Fuel & Aux Air Dampers | Gas Recirc Bypass |
| Primary Air to Mills | Baghouse Cell Isolation |
| Mill Hot Air Control | SCR System Dampers |
| Mill Tempering (Cold) Air | Scrubber Module Isolation |
| Mill Velocity/Volume Air | Flop Gate Coal Diverter |
| Mill Shut-off | Bottom Ash Hopper |
| Mill Burner Shut-off | Fly Ash Handling Systems |
| Mill Seal Air | Oxidation System Dampers |
| Burner Nozzle Tilt Drives | Fluid Drive Coupling Control: |
| SOFA BOX Dampers | FD, ID, PA, GR Fans, Boiler Feed Pumps |
| SOFA BOX Nozzle Tilt | Turbine Governors |
| Secondary Air Windbox | Stoker Speed Control |
| Air Heater Inlet | Gas Main Inlet to Plant |
| Gas Turbine Exhaust Bypass | |

PM & DM Series - Pneumatic

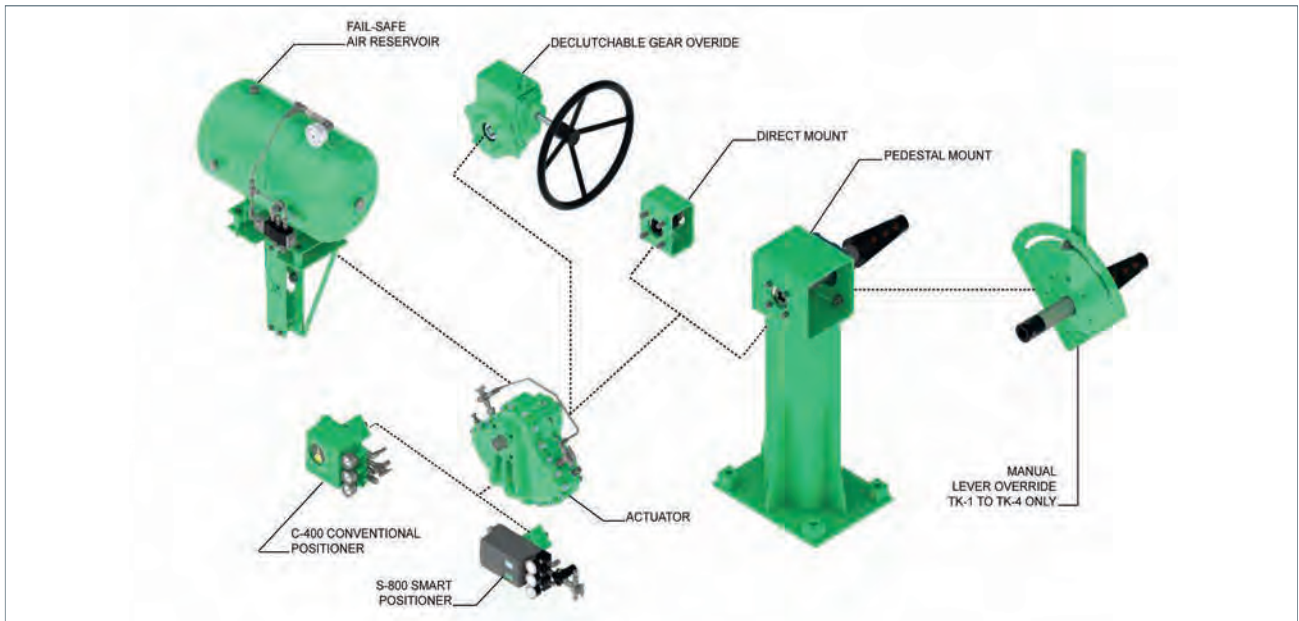

Options:

- High-temperature construction (300 °F / 149 °C)
- Fail-in-Place upon loss of demand signal
- Fail-in-Place upon loss of supply air
- Fail-Safe air reservoir or spring-return
- Explosion-proof electrical ratings
- Mechanical speed controls
- Isolated feedback transmitter (Ohm, analog, digital)
- Discrete alarm / travel switches
- Manual override handwheel or lever
- Demand Signal options:
 - Pneumatic 3-15, 3-27 or 6-30 psi
 - Analog 4 to 20 mA with HART
 - Digital Profibus, Foundation Fieldbus
 - Discrete 120 VAC, 24 VDC, 125 VDC and others
- Combo Particulate / Coalescing Air Filter
- Booster Relays for fast drive rotation

Air Pressure in psig (bar)	Drive Models						
	Drive Torque Output lbf.ft (Nm)						
	TK-1	TK-2	TK-3	TK-4	TK-5	TK-6	TK-7
60 (4.1)	50 (67)	106 (143)	241 (325)	583 (787)	1,341 (1,810)	2,875 (3,881)	6,083 (8,212)
70 (4.8)	60 (81)	127 (171)	286 (386)	691 (933)	1,566 (2,114)	3,441 (4,645)	6,297 (9,730)
80 (5.5)	70 (94)	148 (200)	330 (445)	800 (1,080)	1,800 (2,430)	4,000 (5,400)	8,333 (11,250)
90 (6.2)	80 (108)	168 (227)	373 (503j)	900 (1,215)	2,025 (2,734)	4,541 (6,130)	9,291 (12,543)
100 (6.9)	90 (121)	190 (256)	416 (562)	1,000 (1,350)	2,250 (3,038)	5,000 (6,750)	10,416 (14,062)
110 (7.6)	99 (134)	209 (282)	457 (617)	1,100 (1,485)	2,475 (3,341)	5,500 (7,425)	11,485 (15,505)
120 (8.3)	108 (146)	228 (308)	499 (674)	1,200 (1,620)	2,700 (3,645)	6,000 (8,100)	12,500 (16,875)
Displaced Volume cubic in.	21	44	105	250	511	1,153	2,306
Full-Scale Stroke *Adjustable	1-60 sec.	1-60 sec.	1-90 sec.	1-90 sec.	3-120 sec.	3-180 sec.	3-180 sec.

* Full -Scale Stroke Time, 0-90 degree rotation, no load, can vary based on control components selected

SM-6000 S2 Rotary Drive - Electric

The SM-6000 S2 Series are rotary actuators ideally suited for heavy duty precision damper control. They are internally geared to produce up to 26,000 lbf.ft (35,351 Nm) of torque at unrestricted, continuous modulating duty.

These actuators are ideally suited for dampers, vanes, valves and other process control applications requiring high speed, high torque and exact positioning control.

The SM-6000 S2 actuator features a menu-driven non-intrusive setup using control knobs and vacuum fluorescent display. These controls are also used to program the internally mounted digital amplifier.



SM-6000 S2

Features:

- From 90° to 313° rotation
- Torque range up to 35,251 Nm (26,000 lbf.ft)
- Double o-ring sealing
- Continuous unrestricted modulating duty
- Temperature range from -40 to +85 °C (-40 to +185 °F)
- Automatic torque limiting
- Self-locking drive system to hold in last position and prevent backdriving
- Manual override standard
- HART, Profibus and Foundation Fieldbus available

Applications

- ID Fan Inlet Vane and Outlet Dampers
- FD Fan Inlet Vane and Outlet Dampers
- PA Fan Inlet Vane and Outlet Dampers
- Secondary Air Dampers
- Cyclone Boilers
- Re-heat Air Dampers
- Flue Gas Recirculation Dampers
- Booster Fan Dampers
- Cold/Hot Dampers
- Tempering Air Dampers
- Burner Nozzle Tilts.



Before: Power station in Mexico where gas recirculation damper and FD inlet vane damper control systems are to be replaced.

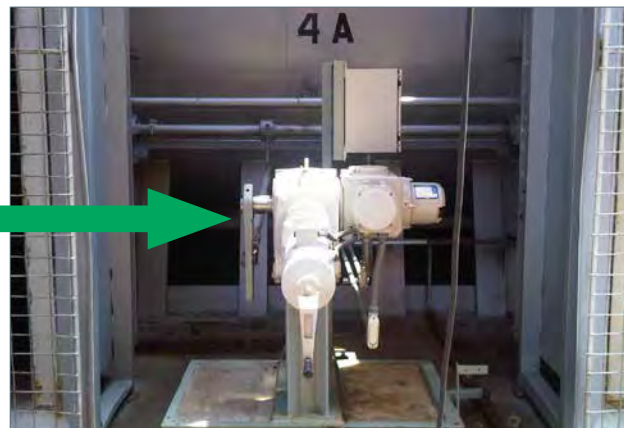

After: SM-6000s installed to improve the efficiency of the plant for tighter control and less maintenance requirements.

SM-6000 S2 Rotary Drive - Electric

Electrical specifications

- **Input Voltage:** 120/1/50-60 ±10%, 240/1/50-60 ±10%, 208/1/50-60 ±10%, 240/3/50-60 ±10% or 208/3/50-60 ±10% amplifier input power.
- **Operating Current:** 10 A nominal at 120/1/60 input.
- **Servo Amplifier:** Digital amplifier, internally or remotely mounted with display and switches mounted on the actuator cover.
- **Electrical Enclosure:** Watertight for outdoor applications.
- **Feedback:** Contactless feedback is standard, potentiometer also available for higher temperatures.
- **Command Signal Input:** 4 to 20 mA, 0-5 VDC, 0-10 VDC through customer supplied shielded cable.
- **Terminal Wiring:** Screw type terminals accepting up to #14 AWG solid or stranded copper wire.
- **Position Transmitter:** 4 to 20 mA isolated, loop powered position transmitter. Requires external power supply. Transmitter ZERO and SPAN are automatically set to actuator ZERO and SPAN, no customer adjustment is required. Operates when power is available to the amplifier.
- **Duty Cycle:** Unrestricted modulating duty.
- **Torque Limiting:** Determined through motor current. Torque is limited to approximately 125-150% of actuator rating.
- **Reverse Acting:** ZERO and SPAN points can be set anywhere in actuator operating range.
- **Incremental Control:** Allows INC/DEC switch operation.
- **Loss of Command Signal:** Selectable Lock-in-place, or move to field settable preset position.

Mechanical specifications

- **Output Torque & Speed:** Refer to selection chart.
- **Output Shaft:** Round with keyway, key supplied.
- **Maximum Travel:** 313 degrees. Greater travel is available as an option; consult factory.
- **Positioning Accuracy:** 0.10% of maximum travel.
- **Repeatability:** 0.10% of maximum travel.
- **Storage Temperature:** -40 to +185 °F (-40 to +85 °C)
- **Ambient Operating Temperature:** -40 to +185 °F (-40 to 85 °C) with integral electronics. Remote mounted electronics allow the actuator to operate in ambient temperatures to 225 °F (107 °C).
- **Lubrication:** Synthetic extreme duty industrial oil.
- **Mounting Position:** Base foot mounted only. An optional motor-up mounting is available, consult factory.
- **Conduit Openings:** Four 1/2 inch conduit openings are provided in the enclosure for customer use.
- **PC Board:** Modular PC board set is easily field replaced for service or upgrades.
- **Handwheel:** A handwheel is provided at rear of motor for manual operation.
- **Loss of Power:** Self locking, up to 150% of load.

Speed/Torque Chart		
Actuator Model	Maximum Output Speed sec/90°	Output Torque lbf.ft (Nm)
SM-6003	10	370 (502)
SM-6005	10	550 (746)
SM-6008	10	800 (1,085)
SM-6014	10	1,400 (1,898)
SM-6025	10	2,500 (3,389)
SM-6044	10	4,400 (5,965)
SM-6062	10	6,200 (8,406)
SM-6080	12	8,000 (10,846)
SM-6110	18	11,000 (14,914)
SM-6165	26	16,500 (22,371)
SM-6260	42	26,000 (35,251)

Popular options

- Extended temperature ranges with remote mounted enclosure to 113 °C (225 °F)
- Drive arm, adapter/clevis kit, drive arm and linkage components
- Additional position limit switches
- Pilot lights, switches, relays
- Faster speeds are available
- Motor-up mounting for tight space applications
- Mechanical position stop plate
- Retrofit Packages
- Various enclosure coatings
- Power failure operation, RP-4000

SM-1700/5000 Series Rotary Drive - Electric

Rotork Process Controls designs and manufactures high quality, durable actuators designed for trouble-free performance under the most demanding conditions.

The SM-1700/5000 Series of rotary actuators are internally geared to produce up to 12,500 lbf.ft (16,950 Nm) of torque, and offer continuous modulation. They are ideally suited for dampers, vanes, valves and other process control applications requiring exact positioning control. All SM-1700/5000 Series actuators are also available with an internal amplifier (excluding SM-1740, SM-1760 and SM-5140). These amplifiers are all full-featured AC switching devices designed to work seamlessly with the actuator for closed loop control.

Features:

- Torques from 50 to 12,500 lbf.ft (67 to 16,950 Nm)
- Rotation 90 degrees to 120 degrees
- Modulating duty: 4,000 starts per hour 120/240 VAC, single-phase supply with DC motor
- Manual override standard
- Automatic torque limiting
- Self locking drive system to hold in last position and prevent back driving up to torque rating
- AC input power (single or three-phase); DC input power version for SM-1700 only
- Temperature range from -40 to 185 °F (-40 to 85 °C)

Amplifier Features:

- Digital position control
- Isolated, two-wire, 4 to 20 mA feedback
- Easy push button set-up and calibration
- Adjustable deadband
- Accepts either voltage or current commands
- Field-selectable fail position for loss of demand signal
- Lock in place
- Run to preset position
- Field selectable dynamic brake



Pedestal mount SM-1700



SM-5000



SM-1700

Options:

- Discrete position switch outputs
- Keyed output shaft
- SM-1700 drive train – spur gearing
- SM-5000 drive train – scotch yoke
 - Provides high seating and unseating torque without oversizing the actuator
- Drive arm, adapter/clevis kit and link arm components
- Auxiliary position limit switches
- Custom mounting and interface hardware
- Local Auto / Manual toggle or key lock rotary switches
- Open-Stop-Close push buttons
- Pilot lights (SM-5000 only)
- Local position indicator

SM-1700/5000 Series Rotary Drive - Electric

Specifications

- Rotation: SM-1700 = 90 to 120 degrees
SM-5000 = 33 to 90 degrees
- Temperature limits: -40 °F to 185 °F
(-40 °C to 85 °C)
- Enclosure: Cast aluminum with polyester powdercoat finish
- Back drive: SM-1700 = self-locking to rated torque
SM-5000 = self-locking to twice rated torque
- Voltage: AC 120/1, 240/1, 208/3, 240/3, 380/3, 480/3, 24 VDC, 90 VDC
 - Check individual specification sheet for each model to verify voltage options available
- Speed: See individual specification sheet for each model to verify available speeds of operation by model
- Field wiring: Barrier terminal blocks
- Switch rating: 120 / 240 VAC, 20 Amp, SPDT switch, one for each direction (CW & CCW)
- Torque limiting: 20 Amp, SPDT switch, one for each direction (CW & CCW). Switch will change states when torque exceeds rated torque for the damper drive (10 AMP switches for SM-1700 & SM-5100)
- Environmental ratings: SM-1700 = NEMA 4 (IP65), dust ignition proof, Class II, Division 1, Groups E, F & G
SM-5100 = NEMA 4 (IP65), Explosion-Proof, Class I, Division 1, Groups C & D, Class II, Division 1, Groups E, F & G
SM-5200, SM-5300, SM-5400 = NEMA 4 (IP65)

SM-5000 Torque Curve

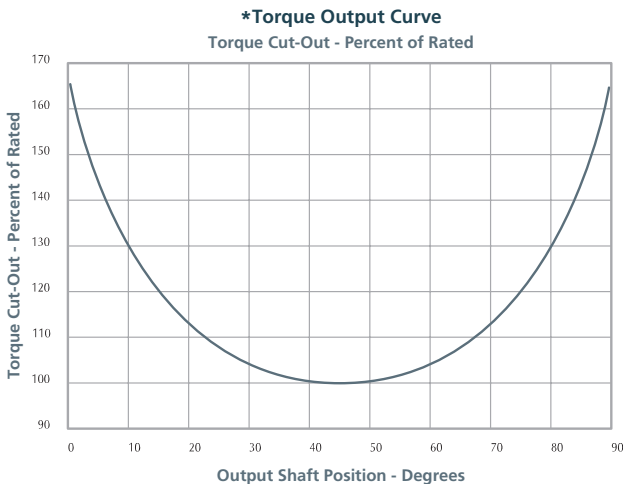

Applicator/Amplifier Specifications

Actuator Model	SM-1715-D, SM-1720-D, SM-1730-D, SM-1740-D, SM-1750-D, SM-1790-D, SM-5115-D, SM-5120-D, SM-5160-D, SM-5190-D, SM-5210-D, SM-5220-D, SM-5260-D, SM-5310-D, SM-5320-D, SM-5360-D, SM-5430-D, SM-5480-D	SM-1760-D, SM-5160-D, SM-5260-D, SM-5360-D, SM-5480-D
Position Accuracy	1.0% of full travel	0.25% of full travel
Repeatability	0.5% of full travel	0.25% of full travel
Hysteresis	0.5% of full travel	0.25% of full travel
Linearity	+/-1% of full travel	+/-0.5% of full travel
Deadband	0.75% of full travel	0.5% of full travel
Resolution	0.75% of full travel	0.5% of full travel

Performance data

Range	Enclosure Certification	*Max. Torque lbf.ft (Nm)	Seconds for quarter-turn at Max. Torque	*Min. Torque lbf.ft (Nm)	Seconds for quarter-turn at Min. Torque	Max. Rotation Degrees	Manual Override	Weight lbs (kg)
SM-1700	IP65 CSA	200 (271)	60	50 (67)	12	120	Yes	40 (18)
SM-5100	IP65 CSA	300 (406)	29	150 (203)	16	90	Yes	80 (36)
SM-5200	IP65	1000 (1355)	28	600 (813)	28	90	Yes	210 (95)
SM-5300	IP65	3200 (4338)	47	1600 (2169)	23	90	Yes	350 (158)
SM-5400	IP65	12500 (16950)	70	5000 (6779)	40	90	Yes	565 (256)

* The SM-5000 Series torque ratings vary with the output shaft position as shown on the Torque Curve graph above. All torques shown in the Performance Data table are at mid-stroke, 45° position. Start and end torque ratings will be 60%+ greater than the mid-stroke rating. Reference PUB041-003 (P002E) for individual torque ratings by model number.

VA Series (Valve Automation) Rotary Actuator - Pneumatic

The Rotork high-performance rotary vane actuator will provide years of service when installed on quarter-turn ball, butterfly or plug valves. Consider Rotork actuators for your most demanding applications, especially high-cycle, high-temperature and precise modulating services.

Rotork VA Series actuators are versatile, modular and available in both double-acting and spring-return configurations. The vane actuator is a 'True Rotary' actuator that does not require the conversion of a linear motion to a rotary motion. Today's flow control equipment must be affordable and provide a measurable return in the form of less downtime, lower energy consumption and lowest overall cost-of-ownership.



Automated Ball Valve

Options

- Open / Close controls
- Modulating controls
- Manual override
- Locking devices
- High-temperature seals to 300 °F (149 °C)



AH Series (Ash Hopper) Rotary Actuator - Pneumatic

The Rotork AH Series high-cycle actuator is ideal for the demanding service found under the precipitators on the ash hopper flap gates. The totally-enclosed design eliminates the high-maintenance cylinder or low-pressure canister actuators that are prone to regular failure.

Problem:

Each time a typical cylinder actuator operates the hopper gate, fly ash that routinely coats the piston rod is drawn back into the cylinder causing eventual seal failure.

Solution:

The Rotork rotary actuator, totally-enclosed with no exposed piston rod, prevents fly ash from entering the actuator and causing damage to the seals.

Rotork provides the engineered mounting hardware to adapt to the existing ash hopper making for a simple and quick installation. We support the AH Series with a 2-million stroke / 3-year performance warranty.

Options

- Direct-mount or remote-mount solenoid valve
- Discrete feedback limit switches
- Manual override

Features:

- Compact / High torque output
- Dual-opposed lip seals
- No pressure-retaining o-rings
- NEMA 4/4x IEC IP66M and IP67M, sealed from the environment
- No 'Pinch-Points' integral to the actuator
- 'No-Play' coupling to eliminate hysteresis and wear



Before

After

CVQ Series - Rotary Electric

The CVQ series is ideal for power stations where process control is critical. The CVA range of quarter-turn actuators provide an electrically powered process control operator suitable for most control valve types and sizes.

CVQ actuators use *Bluetooth*® wireless communication technology that can be used for quick and easy actuator setup auto-calibration and adjustment.

Another popular feature is that all Rotork CVQ actuators incorporate a data logger, which provides an extensive record of such operational and maintenance-related data as valve torque profiles, dwell times, and statistical information.

Applications include:

- Boiler feed water
- Cooling water control
- Water treatment
- Steam control
- Fuel oil
- Variable flow systems
- Spray water control
- Superheat spray valves

Benefits:

- Intuitive user interface
- Datalogger
- High performance
- Stick slip control
- Increased stiffness
- Fail-to-Position
- Increased reliability
- S9 - Continuous unrestricted modulation

CVQ for damper control

The CVQ can also be used to control dampers for precise combustion control offering increased efficiency and reduced emissions.



CVQ Quarter-Turn Actuator



Modbus



IQ3 Series Rotary and Multi-turn Actuator - Electric

Damper drive operation must be reliable and safe. The Rotork IQ3 Series of damper drives are designed to meet the toughest combustion air and flue gas applications and engineered for a lifetime of uninterrupted service in watertight and hazardous area environments. The IQ3 Series damper drives are the most technologically advanced rotary or multi-turn damper drives and valve actuators available to the industry.

TYPE K adapts the proven Rotork IQ3 actuator to combustion air and flue gas applications with additional external bearings necessary to accommodate extraordinary side-loads and engineered floor stands or direct mount linkages to facilitate a quick and easy retrofit to dampers and valves.

Features:

- Torque available:
 - Quarter-turn with IW Gear 185,000 lbf.ft (250,000 Nm)
 - Multi-turn 10 to 30,000 lbf.ft (14 to 40,800 Nm)
- Best in class intuitive display, communications, diagnostics and HMI
- Configurable via *Bluetooth*[®] or Infra-red wireless communications or via local controls
- Full suite of Asset Management standard in detailed datalogger
- High reliability, solid-state controls
- Absolute position measurement with naturally redundant position sensor
- Enhanced sealing and maintenance access
- Full range of supply voltages and communications available
- Thrust compensator to remove thermal expansion in high-temperature services



IQ3



IQ Series on FD Fan Inlet Damper



IQ Series on ID Fan Inlet Damper



Modbus



IQ3 Series Rotary and Multi-turn Actuator - Electric

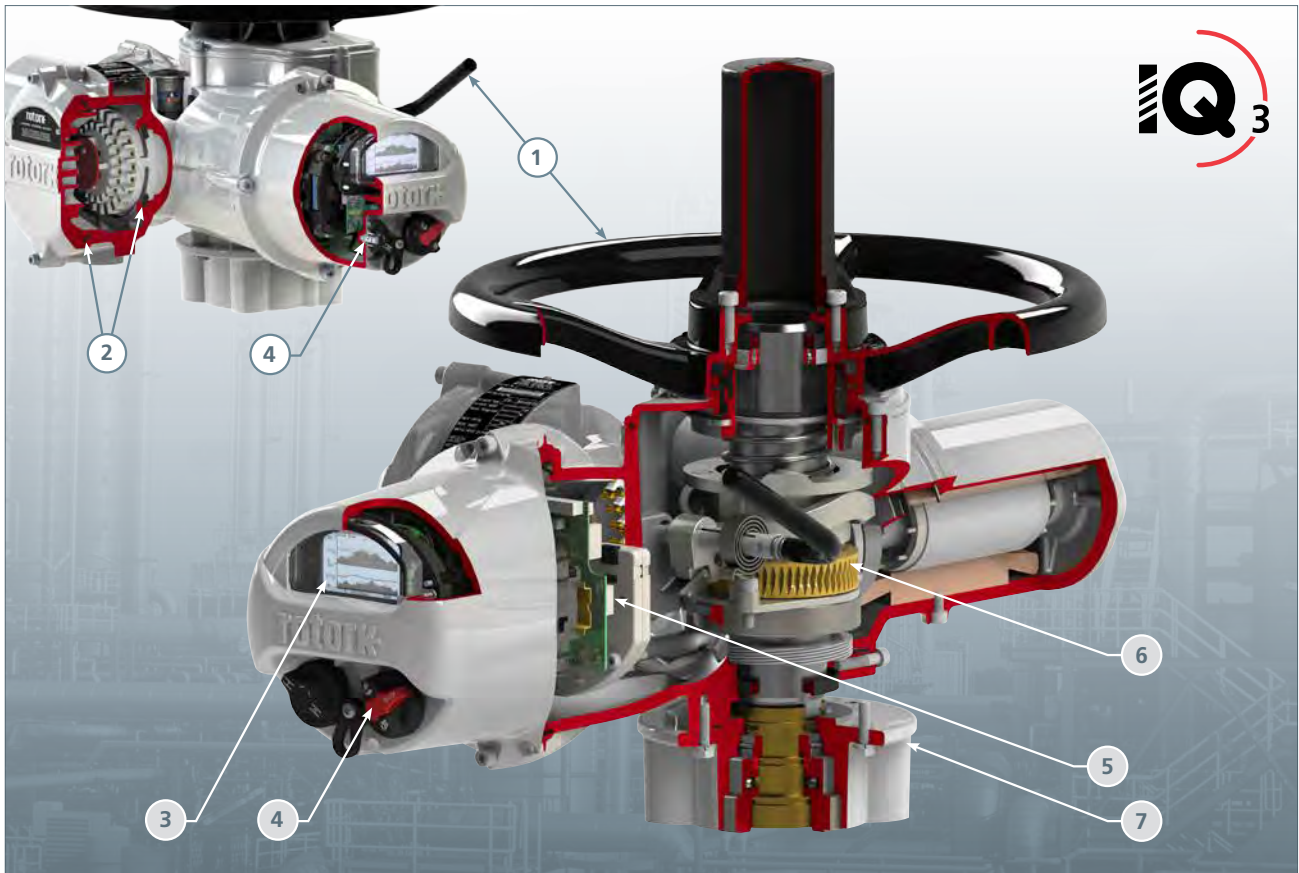

1 Hand operation

Direct drive and geared handwheel sized for effective manual operation of the valve. Handwheel drive is independent of the motor drive and is selected with a lockable hand/auto lever for safe operation even when the motor is running. Motor operation always has preference unless the hand/auto lever is purposely locked into 'hand drive'. Lost motion 'hammerblow' action is provided with both direct and geared handwheels.

2 Environmental sealing

The Rotork double-sealed terminal compartment results in the actuator enclosure being completely sealed, protecting the actuator from the environment for life. Using the supplied Rotork *Bluetooth*® Setting Tool Pro, no covers need to be removed for commissioning, adjusting, analysis or accessing the actuator data log.

3 Display

The advanced dual stacked display is significantly larger, clearer and has a wide viewing angle making it easily legible from a distance. In normal mode the LCD display indicates valve position and can operate from -50 °C up to 70 °C. The matrix layer provides high resolution screens for setting menus, status, alarm and graphical data log screens such as valve torque profiles. Position indication lights (red, yellow and green) are duplicated each side of the display. All display elements are protected by a 13 mm toughened glass window with an optional shield for protection against abrasive media such as sand and UV light.

4 Local controls

Local open/close and lockable Local/Stop/Remote selectors are coupled magnetically to the designated switches and therefore do not penetrate the control cover. This further enhances the non-intrusive protection of the IQ.

5 Position control

The unique Rotork patented absolute position sensor is highly accurate and can measure over 8,000 output turns as standard. With only four active parts it is very simple and robust, providing the most reliable position sensing regardless of the availability of electrical power. It also includes built-in redundancy and self-checking.

6 Proven drive train

The drive train and motor uses the proven basic design principals employed for over 40 years. Simple, reliable and robust, the components are oil bath lubricated (for life).

7 Separable bases

For all sizes the thrust and non-thrust base types are separate to the gearcase allowing easy installation. Should the actuator be removed, the base can be left on the valve to maintain its position. All bases conform to attachment standards ISO5210 or MSS SP 102.

Linear Damper Drive Range





The following pages contain details on performance and specification for the Rotork range of linear damper drive actuators.

Please use the following contents table to help access the information you require.

Linear Damper Drive Range	p21
TYPE K Cylinder Features	p22
CT Series Linear Damper Drive - Pneumatic	p23
JR Series Linear Damper Drive - Pneumatic	p24
LX Series - Pneumatic	p25
LA-2000 Series Linear Damper Drive - Electric	p26
CVL Series - Electric	p28



Linear Damper Drive Range

Rotary Damper Drive Range							
Series	Number of Models	Thrust lbf (N)	Stroke inches (mm)	Starts/Hour	Power Supply	Warranty	Key Features
CT Series Pneumatic 	One (1) Model	460 (2,046)	5 (127)	Unlimited / Continuous Duty	40-150 psi supply air	3-Year Warranty	<ul style="list-style-type: none"> • Windbox drive to control fuel / aux air • "Pin-to-Pin" replacement for Hagan Power Positioner • Rated for high-temperatures up to 300 °F (149 °C) • Virtually no air consumption with S-800 'SMART' positioner
JR Series Pneumatic 	Two (2) Models	1,178-1,885 (5,240-8,385)	1.5-18 (38-457)	Unlimited / Continuous Duty	40-150 psi supply air	3-Year Warranty	<ul style="list-style-type: none"> • Wall-fired burner shroud control damper drive • Power cylinder rated for high-temperatures up to 300 °F (149 °C) • Split-architecture design to move electronics from high-heat area • Field-selectable fail position • Push button control
LX Series Pneumatic 	Twenty (20) Models	Application Specific	Application Specific	Unlimited / Continuous Duty	40-150 psi supply air	3-Year Warranty	<ul style="list-style-type: none"> • Wide variety of bore diameter and stroke lengths • Unique piston rod gland seals to eliminate debris from entering the cylinder • Premium quality design exceeds commercial cylinder performance
LA-2000 Series Electric 	Four (4) Models	550-1,600 (2,446-7,117)	2-24 (51-610)	Up to 2,000	AC 1- or 3-Phase or DC supply	3-Year Warranty	<ul style="list-style-type: none"> • Wide variety of voltage options • Wide variety of stroke lengths and thrust ratings • Easy push button set-up
CVL Series Electric 	Four (4) Models	200-5,000 (890-22,241)	0.1-4.5 (2.5-114)	Unlimited / Continuous Duty	AC 1-Phase, 110/240	2-Year Warranty	<ul style="list-style-type: none"> • Replace spring & diaphragm actuators • Highly accurate with precise control • Bluetooth® wireless communication for easy set-up and adjustment • Eliminates air consumption



TYPE K Cylinder Features

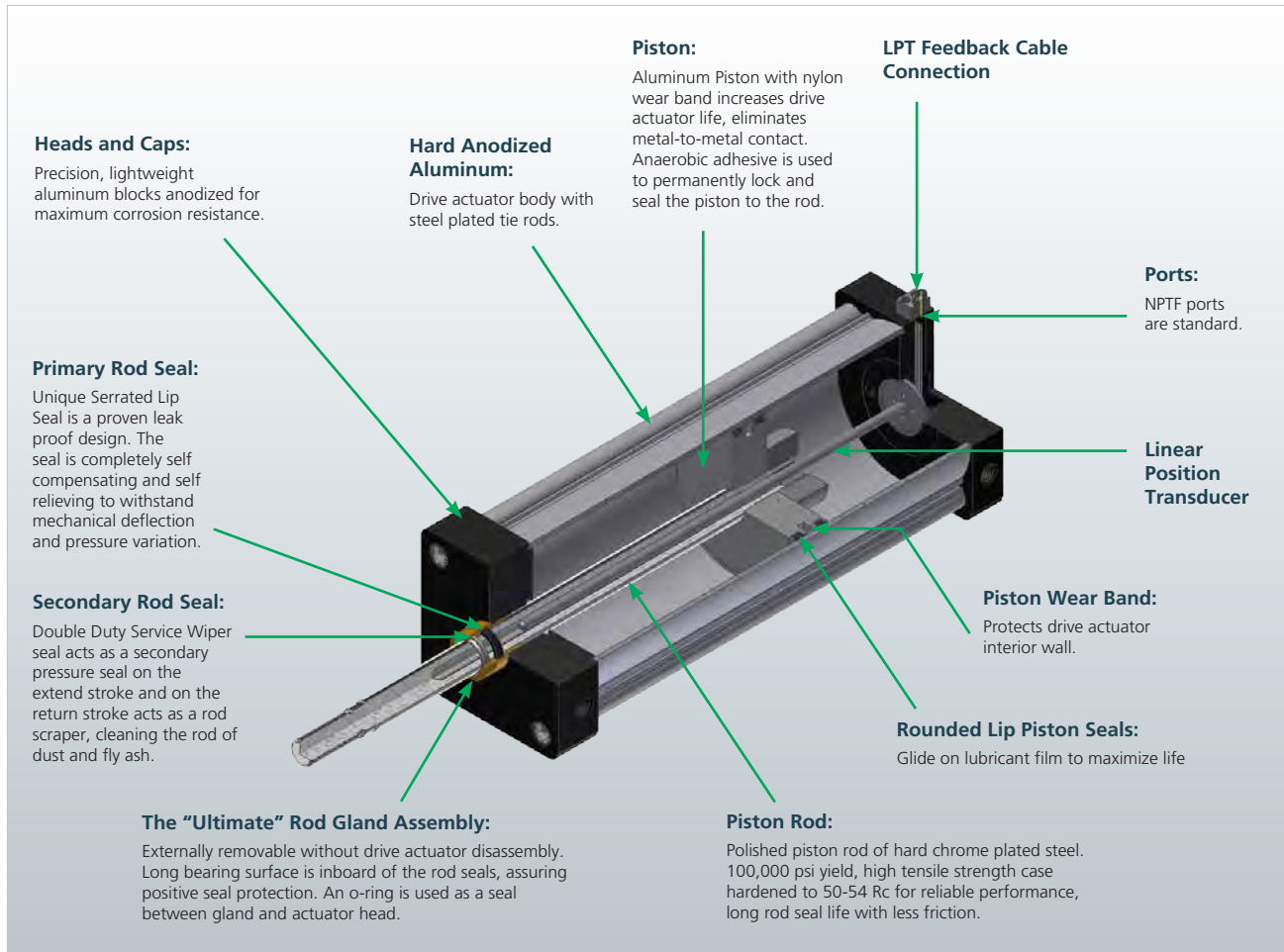

JR Series wall-fired burner shroud

Rotork TYPE K CT Series, JR Series and LX pneumatic series linear damper drives have been designed for the demanding environments found in power plants, refineries and other heavy industries.

Particular emphasis has been placed on protecting damper drive seals and moving parts from coal dust and fly ash and maximizing the temperature ratings.

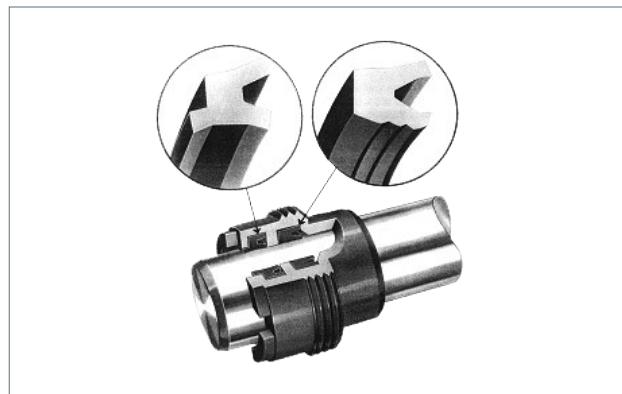

LX Series cylinder rod seal

Together with robust controls, the Rotork linear product range is the most complete offering of pneumatic and electric damper drives available.

Most Rotork TYPE K power cylinders are available with a Linear Position Transducer (LPT) suitable for high-temperature installations. The LPT is mounted inside the cylinder at the center of the piston rod and is rated for a maximum temperature of 300 °F (149 °C) and is connected to a remote-mount positioner with a multi-pin connector.

CT Series Linear Damper Drive - Pneumatic

The TYPE K CT Series linear drive was designed specifically for fuel air and auxiliary air applications on CE / T-Fired / Corner-fired boilers. The CT Series provides excellent and efficient control of the Secondary Air within the windbox and will withstand the extreme heat and vibration common in this application. Effective windbox control will reduce NOx and minimize carbon monoxide (CO) associated with poor fuel-air mixing and will maintain boiler thermal performance.

The CT Series typically replaces legacy Hagan 2.5" x 5.0" power positioners. The CT Series is rear trunnion-mounted and will use the existing pivot post mount that protrudes from the windbox wall. The CT Series cylinder and piston rod clevis dimensions are duplicated for ease of installation, providing a "pin-to-pin" replacement.

The location of the positioner on the CT Series linear damper is field reversible to accommodate adjacent obstructions and to provide installation flexibility.

Features:

- Virtually no air consumption with #S-800 positioners
- Fail-Open upon loss of demand signal (field-reversible to fail-close)
- High-temperature rated to 300° F (149° C) with #C-400 pneumatic positioner
- Continuous duty rated for more than 3600 starts / hour
- Input signal, 3-15 psi, 4 to 20 mA or bus network
- NEMA-4X watertight and dust-tight enclosure
- Permanently lubricated
- Easy field reversible action
- May be mounted in any position
- Auto-calibration with #S-800 'SMART' positioner
- Non-interactive calibration with #C-400 Conventional positioner



CT Series

Options

- Input 3-27 psi, 6-30 psi, HART, Profibus, Foundation Fieldbus
- Hazardous Area explosion-proof ratings
- Various alarm and position switches and transmitter options
- Remote mount positioner for extreme ambient temperature environments
- Cylinder rod baffled covers
- Open / Close controls for non-modulating applications



Thrust				Accuracy	Stroke Length	Resolution	Repeatability	Linearity	Deadband	Stroke Time	Air Supply	Displaced Volume	Air Consumption	
60 psi	80 psi	100 psi	Stall										#C-400	#S-800
276 lbf	368 lbf	460 lbf	690 lbf	0.25% of span	5"	0.09% of span	0.12% of span	0.5% of span	0.12% of span	1.6 seconds	35 - 150 psi	24.5 cu.in.	0.5 SCFM	0.004 SCFM

JR Series Linear Damper Drive - Pneumatic

The JR Series linear damper drive was designed specifically for wall-fired boilers with burners using a combination of fuel and combustion air. Secondary air is introduced at the burner and its ratio to the fuel is regulated by a sliding-sleeve damper to balance the air flow distribution. Effective control of the sliding-sleeve damper will reduce NOx, but the damper drive must be rugged to withstand the harsh environment and capable of continuous and accurate secondary air control.

The JR Series is a high-performance, digitally-controlled, pneumatically-operated linear damper drive suitable for most wall-fired burners. Unlike most pneumatically-operated drives, the JR Series incorporates the fail-in-place characteristics of electric drives while providing unlimited duty-cycle for continuous operation and a high-ambient temperature rating. Additionally, the JR Series has Zero Air Bleed in its resting state.

The JR Series has two major components; the JR Power Cylinder with high-temperature Linear Position Transmitter (LPT) and the DPC-777 Digital Position Controller. This split architecture design allows the electronics to be mounted up to 100 feet away from the Power Cylinder in a more favorable, lower-temperature environment.

Power Cylinder Features:

- 4" dia. (1,178 lbf thrust @ 100 psi)
- 5" dia. (1,885 lbf thrust @ 100 psi)
- 6", 12" or 18" stroke length for each piston diameter
- Unlimited duty cycle – no chance of motor burn-out
- High-temperature construction – rated for 300 °F (149 °C)
- Hi-Temp Linear Position Transducer feedback to DPC-777
- Unique power cylinder twin-seal piston rod gland assembly
- Fail-in-Place or field selectable to fail-extend or fail-retract

DPC - 777 Features:

- Highly accurate to +/- 0.5%
- Push button calibration
- Direct or reverse acting, field selectable
- Reset and Local / Remote pushbutton controls (optional) for manual control
- Stroke reduction to 75% of cylinder piston travel
- Limit switch and continuous position feedback options
- 4 to 20 mA, 1-5, 0-5 or 0-10 VDC input



JR Series cylinder + DPC-777 positioner



Power Cylinder with LPT



Remote Mount Digital Position Controller

LX Series - Pneumatic

The LX Series linear damper drive is proven to be the most reliable, robust and premium quality drive for severe duty applications. The LX Series easily outperforms standard commercial grade cylinders. A properly specified LX Series is capable of operating for millions of cycles in harsh applications with little or no maintenance.

Applications

- Burner nozzle tilt
- SOFA Nozzle tilt
- Mill hot / cold air isolation slide gates
- Mill primary air outlet shut-off valve
- Mill pyrite box cylinder
- Boiler bottom ash hopper sluice gate
- Baghouse inlet louver isolation
- Baghouse outlet poppet style isolation
- Baghouse and electrostatic precipitator ash hopper
- Burner extend and retract oil guns
- Emergency air doors on bottom of furnaces and fired heaters

Features:

- The 'Ultimate' Rod Gland Cleaning System – in harsh environments, the patented rod gland cleans the piston rod as it retracts into the linear drive. This liberated the rod seals, piston seals and rod bearing from abrasive particles, adding years of life to the drive.
- Exact Retrofit – The LX-Series is designed to match the dimensions of the existing linear pneumatic or electric damper drive, eliminating costly field engineering, modifications or fabrication
- Flexibility – Available in 1.5" to 24" bore and any practical stroke length. Quick factory turnaround available for special applications
- Piston Seal – Includes special pressure-compensating lip seals for life expectancy.
- Easily Serviced – Requires no special tools. The 'Ultimate' rod gland assembly can be removed without cylinder disassembly. The drive cap and head are self-aligning with o-ring seals.
- Wide Range of Controls – The LX Series is available with a full array of open/close and modulating controls, including discrete contact, pneumatic, analog, digital or bus network. The positioner may be remote- mounted away from the drive if necessary for operator access or to avoid high temperature.



LX Series



Double-Acting LX-Series Thrust Ratings				
Drive Bore Size (inches)	Thrust (lbf) at Various Supply Pressures			
	60 psi	80 psi	100 psi	120 psi
1 1/2"	87	117	146	175
2"	230	306	383	460
2 1/2"	276	368	460	552
3 1/4"	451	600	751	901
4"	707	942	1,178	1,414
5"	1,131	1,508	1,885	2,262
6"	1,606	2,142	2,678	3,213
8"	2,926	3,902	4,878	5,853
10"	4,567	6,090	7,613	9,135
12"	6,597	8,796	10,996	13,195
14"	8,941	11,922	14,903	17,883



Burner Nozzle Tilt Drive

LA-2000 Series Linear Damper Drive - Electric

The LA-2000 Series are bi-directional linear actuators offering continuous modulating duty up to 2,000 starts per hour. A variety of speeds, thrusts and motors are available which make the LA-2000 Series ideally suited for reliable positioning of dampers, combustion controls, gates, diverters, variable speed drives or other linear positioning applications.

Actuator features:

- Mechanical thrust overload protection
- High modulating duty with internal or remote mounted amplifier
- Self-locking drive system to hold in last position and prevent backdriving up to thrust rating
- Variety of voltage options in single-phase (AC), three-phase (AC) and direct current (DC)
- Permanently lubricated for mounting in any position
- Aluminum NEMA 4 (IP65) enclosure
- Two-year warranty

Amplifier features:

- Analog or digital inputs
- Isolated, two-wire, 4 to 20 mA output transmitter
- HART communication available
- Push button set-up
- Field-adjustable zero and span
- Adjustable Deadband
- Accepts either voltage or current command inputs
- Field-selectable options for Loss-of-Signal
 - Lock in place
 - Run to present
- Digital amplifier proportional control
- Dynamic brake

Applications

- Burner shroud positioning
- Slide gate control, blending, open / close
- Clam shell gates
- Burner Nozzle tilt
- Igniter retract
- Air damper control
- Flop gates
- Diverter operation
- Weigh hopper gates
- Fluid couplings



LA-2400 and LA-2500 Series



LA-2400 Series

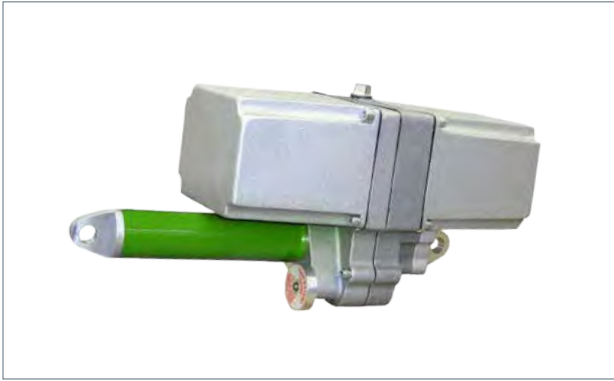

- Thrusts from 150 to 1,500 lbf (667 to 6,672 N)
- Stroke distance from 6" to 24" (152 to 610 mm)
- Modulating Duty: 2,000 starts per hour
- Manual override standard
- HART available
- Automatic thrust limiting
- Anti-condensation heater and thermostat
- Self-locking drive system to hold in last position and prevent backdriving up to thrust rating
- AC input power (single and three-phase) or DC input power versions
- Temperature range from -40 to 150 °F (-40 to 65 °C)

LA-2500 Series



- Thrusts from 800 to 1,600 lbf (3,558 to 7,117 N)
- Stroke distance from 6" to 24" (152 to 610 mm)
- Modulating Duty: 2,000 starts per hour (indoor/outdoor)
- Manual override standard
- HART available
- Automatic thrust limiting
- Anti-condensation heater and thermostat
- Self-locking drive system to hold in last position and prevent backdriving up to thrust rating
- AC input power (single and three-phase)
- Temperature range from -40 to 150 °F (-40 to 65 °C)

LA-2400 & LA-2500 Series Specifications

Model	Input Power Volts/Phase /Hz	Current (Amps) Run Stall	Maximum Thrust lbf. (N) Running Breakaway	Speeds in./sec. mm/ sec.	Command Input	Input Impedance in ohms	Feedback	Modulation Rate*	Dynamic Braking	Loss of Power	Loss of Command Signal
LA-2410-N	120/1/50/60	0.9 1.2	800 (3558)	N/A 0.7 (18)	N/A	N/A	N/A	2000 starts/hour	N/A	L.I.P.	N/A
LA-2410-D	120/1/50/60	0.9 1.2	800 (3558)	N/A 0.7 (18)	4-20 mA, 0-5 VDC or 0-10 VDC	200 100,000	4-20mA loop-powered	2000 starts/hour	Yes	L.I.P.	L.I.P. or R.T.P.
LA-2415-N	240/480/3/50/60	0.3 0.9	1500 (6672)	N/A 0.7 (18)	N/A	N/A	N/A	2000 starts/hour	N/A	L.I.P.	N/A
LA-2420-N	120/1/50/60	2.5 2.9	1500 (6672)	N/A 0.7 (18)	N/A	N/A	N/A	600 starts/hour	N/A	L.I.P.	N/A
LA-2420-D	120/1/50/60	2.5 2.9	1500 (6672)	N/A 0.7 (18)	4-20 mA, 0-5 VDC or 0-10 VDC	200 100,000	4-20mA loop-powered	600 starts/hour	Yes	L.I.P.	L.I.P. or R.T.P.
LA-2440-N	24 VDC	1.7 7.5	550 (2446)	N/A 2.0 (50.8)	N/A	N/A	N/A	2000 starts/hour	N/A	L.I.P.	N/A
LA-2450-N	240/1/50/60	0.45 0.5	800 (3558)	N/A 0.7 (18)	N/A	N/A	N/A	2000 starts/hour	N/A	L.I.P.	N/A
LA-2450-D	240/1/50/60	0.45 0.5	800 (3558)	N/A 0.7 (18)	4-20 mA, 0-5 VDC or 0-10 VDC	200 100,000	4-20mA loop-powered	2000 starts/hour	Yes	L.I.P.	L.I.P. or R.T.P.
LA-2460-N	90 VDC	1.7 1.9	550 (2446)	N/A 2.0 (50.8)	N/A	N/A	N/A	2000 starts/hour	N/A	L.I.P.	N/A
LA-2490-N	240/1/50/60	1.1 1.6	1500 (6672)	N/A 0.7 (18)	N/A	N/A	N/A	600 starts/hour	N/A	L.I.P.	N/A
LA-2490-D	240/1/50/60	1.1 1.6	1500 (6672)	N/A 0.7 (18)	4-20 mA, 0-5 VDC or 0-10 VDC	200 100,000	4-20mA loop-powered	600 starts/hour	Yes	L.I.P.	L.I.P. or R.T.P.
LA-2510-N	380/3/50	2.4 4.7	1600 (7117)	N/A 0.8 (19)	N/A	N/A	N/A	1200 starts/hour	N/A	L.I.P.	N/A
LA-2520-D	120/240/1/50/60	6/3 15/7.5	1600 (7117)	N/A 0.9 (23)	4-20 mA, 0-5 VDC or 0-10 VDC	200 100,000	4-20mA loop-powered	1200 starts/hour	-	L.I.P.	L.I.P. or R.T.P.
LA-2520-E	120/240/1/50/60	6/3 15/7.5	1600 (7117)	N/A 0.9 (23)	4-20 mA, 0-5 VDC or 0-10 VDC	200 100,000	4-20mA loop-powered	1200 starts/hour	-	L.I.P.	L.I.P. or R.T.P.
LA-2520-D	120/240/1/50/60	6/3 15/7.5	1600 (7117)	N/A 0.9 (23)	N/A	N/A	N/A	1200 starts/hour	N/A	L.I.P.	L.I.P. or R.T.P.

* Minimum position change of 1%, L.I.P. = Lock-in-Place, R.T.P. = Run to Position, N/A = Not Applicable

CVL Series - Linear Electric

The CVL series is ideal for power stations where process control is critical. The CVA range of quarter-turn actuators provide an electrically powered process control operator suitable for most control valve types and sizes.

CVL actuators use *Bluetooth*[®] wireless communication technology that can be used for quick and easy actuator setup auto-calibration and adjustment.

Another popular feature is that all Rotork CVL actuators incorporate a data logger, which provides an extensive record of such operational and maintenance-related data as valve torque profiles, dwell times, and statistical information.

Applications include:

- Boiler feed water
- Cooling water control
- Water treatment
- Steam control
- Fuel oil
- Variable flow systems
- Spray water control
- Superheat spray valves

Benefits:

- Intuitive user interface
- Datalogger
- High performance
- Stick slip control
- Increased stiffness
- Fail-to-Position
- Increased reliability
- S9 - Continuous unrestricted modulation



CVL Linear Actuator

CVL for damper control

The CVL can also be used to control dampers for precise combustion control offering increased efficiency and reduced emissions.



The CVL-1200 was chosen because it provides extremely precise control-valve operation with repeatability and resolution performance at less than 0.1% of full scale.



Modbus



Accessories

Accessories	
	<p>DPC-777 Digital Remote Mount Positioner</p> <ul style="list-style-type: none"> • For use on any pneumatic damper drive • Remote-Mount Digital Position Controller • +/- 0.5% accuracy & repeatability
	<p>C-400 Conventional Positioner</p> <ul style="list-style-type: none"> • For use on any pneumatic damper drive • Non-interactive zero and span calibration • Install I/P converter, analog output and limit switches internally
	<p>S-800 'SMART' Digital Positioner</p> <ul style="list-style-type: none"> • Push button set-up and auto-calibration, HART, Profibus and Foundation Fieldbus capable • Extensive diagnostic functions • Virtually zero air consumption in resting state
	<p>AFS Air-Fail-Safe</p> <ul style="list-style-type: none"> • Integral air accumulator to fail damper to desired Open or Closed position • Triggered on loss of air, electrical or both • Economical, field-reversible, light-weight
	<p>Rotork Fairchild TXI7800 I/P Converter</p> <ul style="list-style-type: none"> • Explosion-proof NEMA 4x, IP65, Type 4 enclosure • Field reversible for direct or reverse acting • RFI / EMI protection eliminates electromagnetic interference
	<p>Rotork Fairchild T6100 Fail-Last I/P Converter</p> <ul style="list-style-type: none"> • Locks in "last position" upon loss of demand signal • Extremely low drift after power loss • Mount to damper drive or remote mount for convenience
	<p>WB-1000 Windbox bearing upgrade</p> <ul style="list-style-type: none"> • Replace windbox cylinder shaft levers that side load original hex nut bearing • Eliminate shaft binding and secondary air leaks • Self-aligning and self-lubricating bearing
	<p>950 Series Auto/Manual Control Station</p> <ul style="list-style-type: none"> • For use on any pneumatic damper drive • Switch from Auto to Local control of modulating pneumatic final control elements • Low profile, compact, rugged
	<p>Combination Air Filter</p> <ul style="list-style-type: none"> • 5 Micron Particulate + 0.01 Micron Coalescing • Removes liquid aerosols and submicron particles • Automatic float drain



Rotork Site Services

rotork® Site Services

In each of our divisions, site services staff are dedicated to providing customer service and support, carrying out new installations and delivering retrofit projects. These teams are based out of service centres around the world and are complemented by factory-trained agents.

Our expert technicians support Rotork customers, allowing us to deliver on our promise of global solutions backed by local service.

Visit www.rotork.com to identify your nearest Rotork Site Services centre.

Emergency and Planned Service

We provide a full range of actuator services, covering any type of actuator in any location, including hazardous environments. Our services include installation, commissioning and upgrading as well as connection and installation of bus communication systems. We are also skilled at troubleshooting and repairing damaged or deteriorating assets. Depending on your requirements, we can offer guaranteed emergency response times or planned response.

Actuator Overhauls

After a long service life it is sometimes preferable to overhaul rather than replacing actuators. In our workshops we completely strip and rebuild actuators, returning them to their original state.



Health Checks

To help customers understand the state of their plant and assets, to better inform maintenance and replacement decisions, we offer full inspection and reporting. In addition to a detailed and intrusive inspection of the actuators, we offer extra insights from our original factory build data.

Preventative Maintenance

To maximize plant up-time and minimize operating costs we offer clients a range of preventative maintenance programs. We tailor the service in every case to reflect the type of actuators in service, the availability of asset information and the criticality of the plant.



Worldwide Support

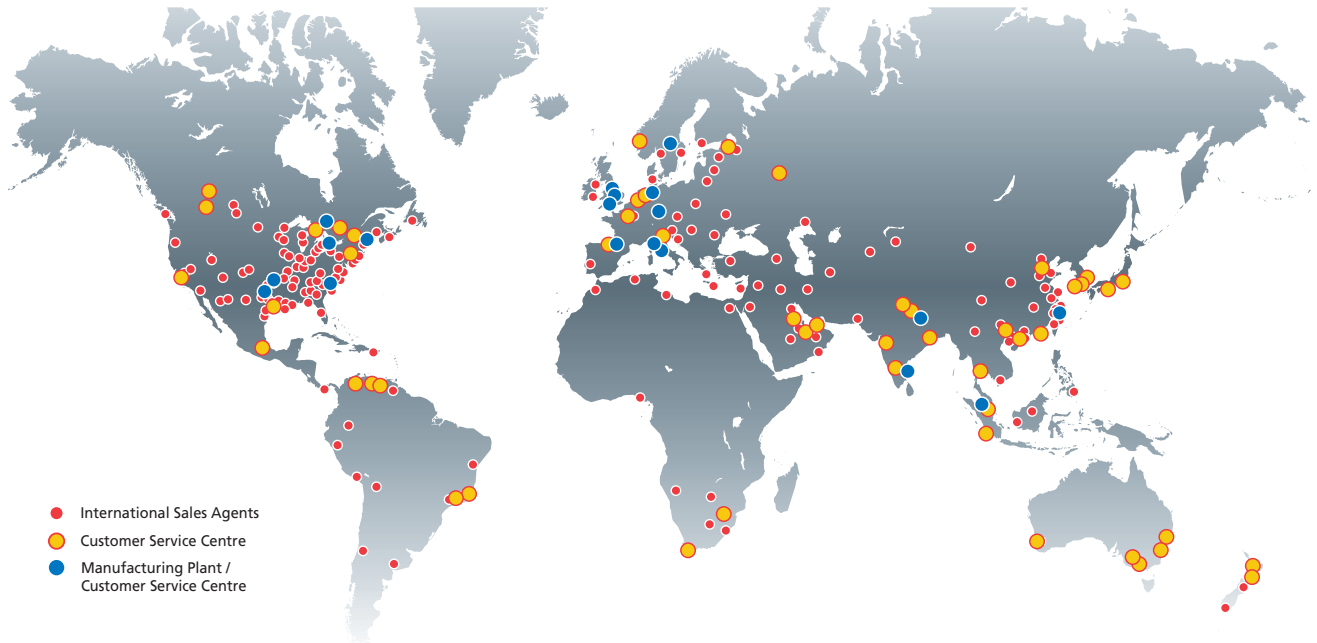

Retrofitting Actuators to Existing Valves

We have extensive experience in fitting actuators to valves, penstocks and dampers that are already installed as part of existing plant. Whether customers are replacing obsolete actuators, changing power sources or motorizing manual valves, we offer a tailor made solution to meet customers' specific requirements.

Shutdown Outages

For those customers who run tightly-scheduled shutdowns, we engage closely in the project to help meet demanding deadlines. A typical example might involve our staff removing large numbers of actuators, overhauling them in our workshops and re-commissioning them as part of the maintenance of a larger unit.



Factory Fitting of Actuators to New Valves

The careful assembly of valve and actuator is critical to ensure that an automated valve performs correctly and reliably. Whilst this service is often carried out by valve manufacturers, if there is a need we can provide this service.

Extended Scope Projects

This is a growing requirement and some of our service teams have the wide range of skills necessary to offer a "one-stop-shop" to automate part or all of a customer's process. Our capabilities cover all of the installation phases (scoping, design, procurement, manufacturing, installation, commissioning) on the broad scopes that typically surround actuation projects.



rotork[®]

Redefining Flow Control



www.rotork.com

A full listing of our worldwide sales and service network is available on our website.

Rotork plc
Brassmill Lane, Bath, UK
tel +44 (0)1225 733200
fax +44 (0)1225 333467
email mail@rotork.com

USA
TYPE K Rotary + Linear Damper Drives
tel +1 (214) 343 9980
fax +1 (214) 343 9653
email info@typek.com