

# CheckAll<sup>®</sup> VALVE



**Serving Customers Around  
the World for Over 50 years.**

# CHECK-ALL VALVE

Check-All Valve® Mfg. Co.  
1800 Fuller Road  
West Des Moines, IA 50265 U.S.A.  
Phone: 515-224-2301  
Fax: 515-224-2326  
Website: [www.checkall.com](http://www.checkall.com)  
E-mail: [sales@checkall.com](mailto:sales@checkall.com)

Introduction to Company and Products ..... 1  
Certifications & Compliances..... 2  
Order Information..... 3  
**OUR CHECK VALVES BY CONNECTION TYPE** ..... 5 - 47

## Flange

### Flange Insert

- F1
- F6
- FP

page 5



### Wafer Insert

- WV

page 9



### Horizontal-Vertical Flanged & Drilled

- HV

page 11



## Threaded

### Bushing

- BU
- BR

page 13



### Connector

- CN
- CR

page 15



### Universal Low Pressure

- U3
- UR

page 17



### Universal High Pressure

- U1
- R1

page 19



### Mini Check

- M1 - M8

page 21



## Sanitary

### 3-A Sanitary Check

- 3S  Third Party Verified

page 23



### Sanitary Cartridge

- SC

page 27



### Sanitary Insert

- CB
- TC

page 29



# CHECK-ALL VALVE

## OUR CHECK VALVES BY CONNECTION TYPE

### Welded

#### Butt Weld

- B4
- B8

page 31



#### Universal Socket Weld

- US

page 33



### Tubing

#### Tubing Check

- TV

page 35



#### Tubing Check Flared

- TF

page 37



### Lined Pipe

#### Lined Pipe Insert

- LP

page 39



#### Horizontal-Vertical Flanged & Drilled PTFE Lined

- HT

page 41



### Unique

#### Straight Sided Insert

- SI

page 43



#### Union Insert

- UV

page 45



#### Custom

- CAV

page 47



Additional Products and Services .....	48
Technical Data .....	49
Application Guidelines .....	50
Installation and Operating Instructions .....	51
Body Material Definition for Check-All Valve® Products.....	53
Pressure Equipment Directive (PED 2014/68/EU) Conformance Statement .....	55
Check-All® Order Form .....	57
Manufacturer's Terms and Conditions of Sale.....	58
Warranty.....	59

**PROUDLY MADE IN THE USA**

***In the beginning . . .*** the first **Check-All®** valve was designed and built for use as a pump foot valve; the year was 1958. Since then **Check-All®** has grown from an idea to a reality; from one valve to many series of valves; from one use to multiple uses; from one material; to a variety of materials and from one man to a factory. **Check-All®** has grown in all respects — but one element remains the same — SERVICE TO EACH CUSTOMER. We will never permit this to change.

**Design Features** — The complete line of Check-All® valves are in-line spring-loaded poppet-type check valves. Many series are available to provide check valves for practically every service application. Check-All® valves are available with metal to metal or soft seats. Sizes range from 1/8" NPT to 20 inch flange connections. Pressure ratings are available from full vacuum to 10,000 psi. Special materials include Titanium, Alloy C-276, Alloy 400 or MONEL®, Alloy 20 and many others. A wide range of spring settings is available for all valves. Fluoropolymer (FEP) encapsulated springs are available for special corrosion applications. The following are some of the reasons Check-All® is an outstanding source for all your check valve, vacuum breaker and low pressure relief applications:

**SILENT** — engineered for silent operation! Check-All® valves close quickly and smoothly to minimize hammer noise.

**ORIFICE SIZE** — engineered from empirical data to give a minimum pressure drop over the full flow range of the valve.

**BASIC DESIGN** — streamlined so that fluid flows through the valve over smooth contoured surfaces with a minimum change in direction, thereby minimizing pressure drop.

**INDUCED TURBULENCE** — on seating surfaces just before the valve closes, ensures positive sealing by removing minute foreign particles suspended in the fluid.

**SEATING SURFACES** — all metal valves are mated and precision lapped to ensure effective sealing. The parts remain mated through the assembly process.

**DESIGNED** — to function *equally well* in either a vertical or horizontal position, with proper spring selection.

**DESIGNED** — to *reduce* installation costs, the Insert series check valves easily fit into existing line components which reduces both initial cost and installation time.



**DESIGNED** — to reduce maintenance costs, the Check-All® design is simple, rugged and efficient. The seating surfaces are parallel to each other, thereby eliminating the excessive wear occurring in plug, cone and ball seats.

**DESIGNED** — with the spring upstream of the seat, strategically placing it outside any mixing and potentially aggressive solutions.

**VERSATILE** — Check-All® valves also can be used as **LOW PRESSURE RELIEF VALVES** and **VACUUM BREAKERS**.

## Certifications & Compliances

**ISO 9001** Check-All Valve® is an ISO 9001 Certified company. Our certificate number is FM 40858 and is issued by The British Standards Institution (BSI). This certification indicates that Check-All® products are designed, manufactured and distributed in accordance with ISO 9001 requirements. That means when you order Check-All Valve® products you are assured of receiving the highest quality check valves; consistently and on-time.

 **Sanitary Standards** The Check-All® style 3S check valve is compliant with 3-A Sanitary Standards for Vacuum Breakers and Check Valves for Milk and Milk Products Number 58-01 and has been Third Party Verified by a Certified Conformance Evaluator. Among other requirements, this is a standard that requires a 32 Ra finish and specified groove angles and depths, all for sanitary purposes. Consult the factory if finer surface finishes are required.

**B16.34 Certification** Some valve sizes can be supplied with B16.34 certification. Consult factory for more information.

**Canadian Registration Number** Check-All Valve® also has obtained a Canadian Registration Number (ØC163Ø1.2CL) for many of its products. The CRN is required for some products to be installed in certain applications in Canada. Check-All® has registration in all provinces and territories of Canada. Consult the factory if you require a valve with a CRN.

**CE (PED 2014/68/EU) Conformance** Many Check-All Valve® products conform to the Pressure Equipment Directive (PED 2014/68/EU). Our certificate number is CE62128 and is issued by The British Standards Institution (BSI) who is our Notified Body for conformance under assessment Module H (full quality system). Please see page 55 for additional information regarding CE conformance.

**NACE Standards** Check-All Valve® can supply valves that conform to the requirements of NACE MR0175/ISO 15156 and NACE MR0103/ISO 17495-1. Valves conforming to NACE are hardness tested based on the user-selected materials of construction. Contact the factory for details and availability.

# ORDER INFORMATION

Also See Valve Application Guidelines on Page 50

**WARNING: Do not install on the discharge of a reciprocating air compressor or directly on the outlet side of an elbow. Valves are designed for fully developed flow.**

**Check-All®** valves are completely described by — **Style** designation and combinations of **Letters** and **Numbers**. The appropriate combinations will designate: **Style, Size, Body Material, Seat Material, Spring Cracking Pressure and Spring Material.**

## A. Materials:

Internal materials may differ from body materials. Consult the factory for details. See page 53 for additional comments regarding material definition.

### 1. Body Materials: ❶

SS – 316 Stainless Steel (-325°F to 700°F)	TF – Fluoropolymer (PTFE) (-325°F to 400°F)
BR – Brass (-325°F to 400°F)	PV – PVC (+32°F to 150°F)
CS – Carbon Steel (-20°F to 700°F)	A2 – Alloy 20 (-325°F to 600°F)
MO – Alloy 400 or MONEL® (-325°F to 500°F)	HC – Alloy C-276 (-325°F to 1000°F)
TI – Titanium (-75°F to 500°F)	HB – Alloy B (-325°F to 800°F)

### 2. Seat Materials: ❶

All valve seats are integral and can be supplied either with an o-ring seat or without an o-ring (metal-to-metal seat). Whether the valve body is metal or plastic, the term “metal-to-metal” is used for seats without o-rings. “Metal-to-metal” seats are the same material as the valve body unless otherwise specified. ALL O-RING SEATS HAVE A MAXIMUM PRESSURE RATING OF 1500 PSI. Many compounds below are also available in USP Class VI, FDA and 3-A compliant materials; however, temperature ranges of these compounds may differ. Please consult factory for details. See page 4 section B for more information on seat leakage or consult the factory for assistance.

VT – VITON® (-10°F to 400°F)	MT – Metal-to-Metal (or same as body material)
BN – Buna-N (-40°F to 250°F)	AS – AFLAS® (+10°F to 400°F)
EP – EPDM (-65°F to 300°F)	KZ – KALREZ® (0°F to 525°F)
NE – Neoprene (-40°F to 250°F)	3S – 3-A Silicone (-80°F to 450°F)
TF – Fluoropolymer (PTFE) (-325°F to 500°F)	US – USP Class VI Silicone (-80°F to 450°F)

*TF not available for plastic valves.*

❶ Temperature ranges given are for ideal service conditions and may vary. Material selection for a specific application is the responsibility of the customer.

**B. Seat Leakage:**

Resilient soft seats are required for “bubble tight” shutoff. Consult the factory for information on “metal-to-metal” or PTFE seats. “Metal-to-metal” and PTFE seats are not resilient. See page 50 for allowable leakage rates.

**C. Springs: ❶**

All standard springs are 316 stainless steel unless noted otherwise. Several cracking pressure options are available for each valve. Spring sizes are defined by the orifice diameter of the valve.

- SS – 316 Stainless Steel (-325°F to 400°F)
- PH – 17-7 PH Stainless Steel (-20°F to 400°F)
- HC – Alloy C-276 (-325°F to 400°F)
- HB – Alloy B (-325°F to 400°F)
- MO – Alloy 400 or MONEL® (-325°F to 400°F)
- IX – Alloy X750 or INCONEL® Alloy X750 (-325°F to 700°F)
- TI – Titanium Beta C (-75°F to 550°F)

Consult the factory for other available spring materials or higher temperature applications. Higher alloy material valves use higher alloy springs.

**D. Fluoropolymer (FEP) Encapsulated Springs:**

Springs are encased in heat shrinkable FEP tubing. The ends of the tubing are plugged with FEP rod and sealed. When ordering FEP encapsulated springs add the letter “T” as a suffix to the cracking pressure and spring material specified. FEP encapsulation may reduce flow capacity and the cracking pressure may vary. Temperature range for FEP encapsulation material is -325°F to 400°F. Some springs for 0.348 and 0.464 orifice diameters are not available with FEP encapsulation. Consult the factory for a substituted spring.

**E. Special Springs:**

Special alloys or special cracking pressures are available for all valves. Higher cracking pressure springs may reduce flow capacity. Consult the factory for price and delivery.

❶ Temperature ranges given are for ideal service conditions and may vary. Material selection for a specific application is the responsibility of the customer.

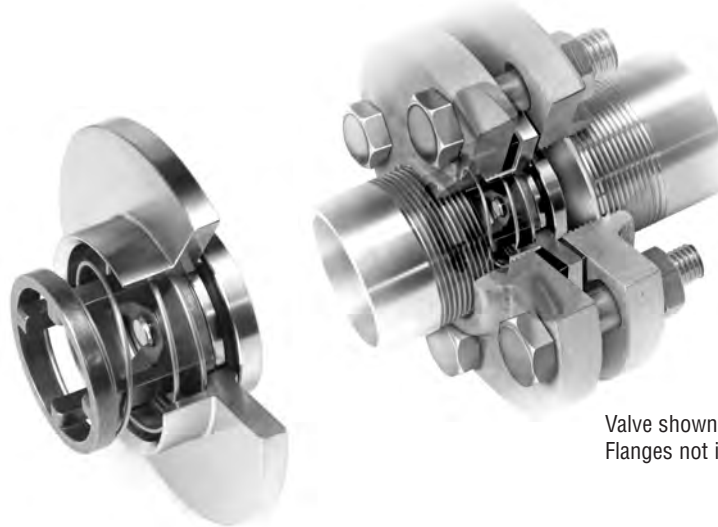
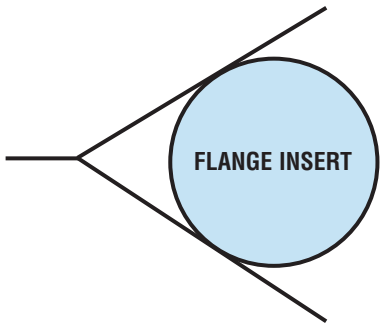

Valve shown in flanges.  
Flanges not included.

The **Flange Insert (F1, F6, FP)** valves are the ultimate check valve in flanged systems. They provide the simplest and most economical way to install check valves in a piping system. The valve body helps position itself while bolts are being installed and tightened. Two gaskets are required instead of the one normally used in a flanged joint. See page 51 or consult the factory for additional installation guidelines.

Flange Insert valves are designed to fit between two mating ANSI flanges. The “Spring Housing”, designated by the “A” dimension<sup>①</sup>, is designed to be inserted into the upstream pipe, thereby helping to center it in the pipe. Therefore, there must be clearance between the spring housing and the pipe or flange. Generally speaking, the FIV Class 150 and 300 valves (F1) are designed for standard schedule pipe with Class 150 or 300 flanges, and the FIV Class 600 (F6) valves are designed for schedule 80 pipe with Class 150, 300 or 600 flanges.

The Flange Insert valve can also be used as a low pressure relief valve or vacuum breaker by using the desired spring settings.

**NOTE:** Many valves in this series can be supplied with B16.34 certification. Consult the factory for more information.

Body Material <sup>②</sup>	Nominal Pipe Size	Non-Shock Pressure-Temperature Rating		
		ANSI Class 150	ANSI Class 300	ANSI Class 600
316 Stainless Steel (SS) Carbon Steel (CS) Alloy 20 (A2) Alloy C-276 (HC) Alloy B (HB) Alloy 400 or Monel <sup>®</sup> (MO) Titanium (TI)	1/2" - 4"	X	X	X
	5" - 20"	X		
Brass (BR)	1/2" - 4"	X	X	
	5" - 20"	X		
PTFE (TF)	1/2" - 1-1/2"	55 PSIG @ 100°F <sup>③</sup>		
	2" - 6"	20 PSIG @ 100°F <sup>③</sup>		
PVC (PV)	1/2" - 6"	200 PSIG @ 100°F <sup>③</sup>		

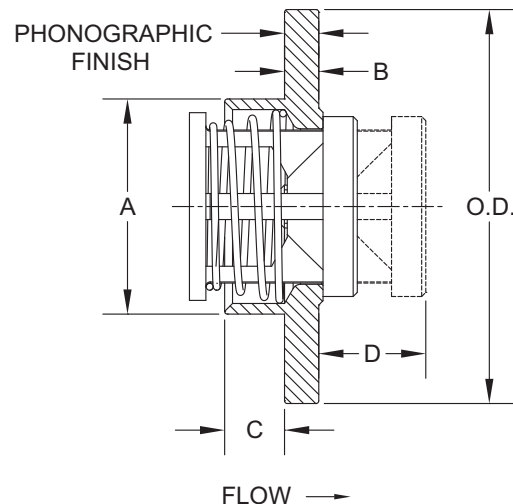

<sup>①</sup>Check “A” dimension for clearance with pipe ID. Generally “A” dimension is designed for use in schedule 40 pipe for class 150 & 300 valves (F1). Order class 600 (F6) valves for schedule 80 pipe.

<sup>②</sup>See pages 53-54 for material grade information.

<sup>③</sup>Consult the factory for reduced P-T rating above 100°F. Standard spring material is 316 Stainless Steel.



See Diagram on Page 5

(F1, F6, FP) Dimensions

Nominal Pipe Size	Size Code	ANSI Rating & Material	A	B	C	D ①	O.D.	Orifice ② Diameter
1/2	D	150 & 300 600 PTFE & PVC	0.605 N/A ③ 0.600	1/4	0.29 N/A ③ 0.27	0.55 0.53 0.68	1-3/8	0.348
3/4	F	150 & 300 600 PTFE & PVC	0.762 0.719 0.720	1/4	0.26 0.24 0.26	0.63 0.62 0.77	1-3/4	0.464
1	H	150 & 300 600 PTFE & PVC	1.000 0.922 0.930	1/4	0.36 0.33 0.36	0.81 0.80 0.81	2	0.593
1-1/4	I	150 & 300 600 PTFE & PVC	1.340 1.234 1.240	1/4	0.44 0.39 0.59	0.88 0.87 0.99	2-1/2	0.890
1-1/2	J	150 & 300 600 PTFE & PVC	1.570 1.490 1.490	1/4	0.44 0.40 0.69	1.04 1.03 1.11	2-7/8	1.135
2	K	150 & 300 600 PTFE & PVC	2.005 1.890 1.890	1/4	0.49 0.43 0.52	1.21 1.21 0.93	3-5/8	1.385
2-1/2	L	150 & 300 600	2.407 2.266	1/4	0.66 0.59	1.45 1.45	4-1/8	1.555
3	M	150 & 300 600 PTFE & PVC	3.006 2.844 2.865	5/16	0.70 0.65 0.73	1.63 1.62 1.62	5	2.025
4	N	150 & 300 600 PTFE & PVC	3.964 3.766 3.766	3/8	1.00 0.96 1.00	1.93 1.93 2.04	6-3/16	2.560
<b>Sizes 5" and larger are only available in class 150. Consult the factory if using Schedule 80 pipe.</b>								
5	O	150	4.985	1/2	1.07	2.14	7-5/16	3.280
6	P	150 PTFE & PVC	6.003 5.700	3/8 9/16	1.52 1.55	2.22 2.78	8-1/2	3.875
8	Q	150	7.919	1/2	2.27	3.14	10-5/8	5.110
10	R	150	9.958	1/2	2.84	3.58	12-3/4	6.380
12	S	150 Brass Other Metals	11.876	5/8 1/2	3.12 3.25	4.33 4.18	15	7.670
14	T	150 Brass Other Metals	13.062	11/16 1/2	3.18 3.37	4.58 4.45	16-1/4	8.460
16	U	150 Brass Other Metals	14.938	3/4 9/16	3.69 3.88	5.20 5.05	18-1/2	9.650
18	V	150 Brass Other Metals	16.814	7/8 5/8	3.87 4.12	5.80 5.63	21	10.860
20	W	150 Brass Other Metals	18.750	15/16 11/16	3.88 4.13	6.54 6.26	23	12.110

① Maximum nominal dimension for a fully open valve with no spring.

② Due to molding process, orifice in plastic valves may vary.

③ Style F6 size "D" does not have a spring housing.

**Flange Insert**  
 Flow Curves assume Schedule 40 pipe  
 For Water at 72°F

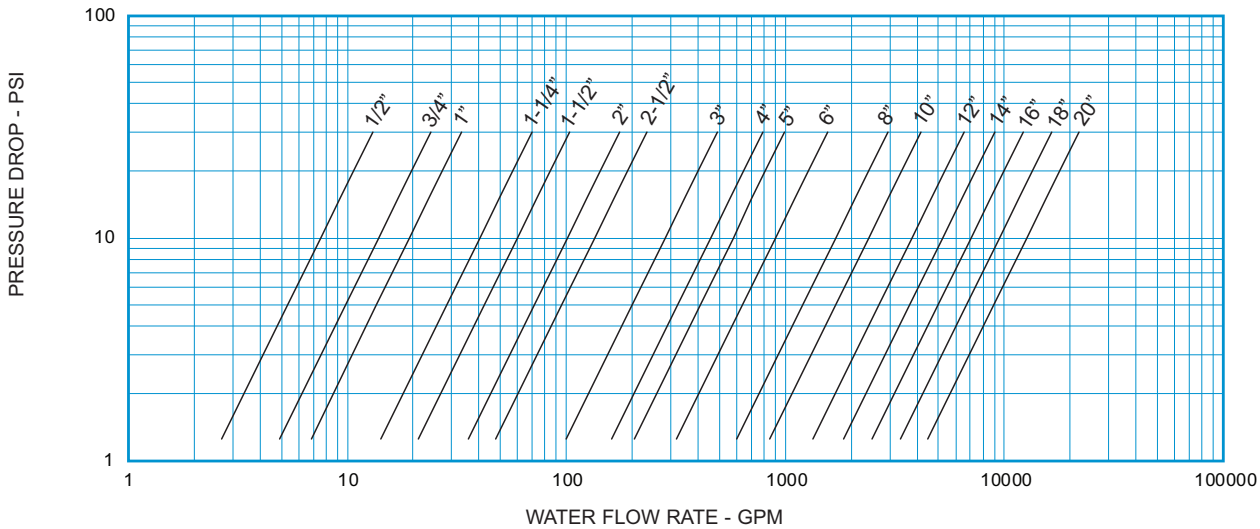

**Note:** All flow curves and Cv values presume the valves are fully open with 1/2 PSI cracking pressure springs. Consult the factory for more information.

STYLE F1, F6, FP C <sub>v</sub> VALUES & VALVE WEIGHTS					
C <sub>v</sub>	SIZE	SS & CS ALLOYS	BRASS	PTFE	PVC
2.4	1/2	1.7 oz.	1.9 oz.	0.5 oz.	0.3 oz.
4.4	3/4	2.9 oz.	3.2 oz.	0.8 oz.	0.5 oz.
6.1	1	4.2 oz.	4.6 oz.	1.1 oz.	0.7 oz.
12.7	1-1/4	7.0 oz.	7.4 oz.	1.9 oz.	1.4 oz.
18.8	1-1/2	9.5 oz.	9.8 oz.	2.6 oz.	1.7 oz.
32.0	2	16.3 oz.	17.3 oz.	3.8 oz.	2.6 oz.
42.5	2-1/2	1.4 lb.	1.5 lb.	---	---
89.0	3	2.3 lb.	2.6 lb.	9.6 oz.	6.1 oz.
144	4	4.9 lb.	5.3 lb.	1.2 lb.	12.7 oz.
182	5	8.2 lb.	8.7 lb.	---	---
284	6	12.3 lb.	13 lb.	1.8 lb.	1.2 lb.
535	8	24.4 lb.	26.4 lb.	---	---
757	10	36.3 lb.	44 lb.	---	---
1200	12	51 lb.	58 lb.	---	---
1650	14	74 lb.	93 lb.	---	---
2230	16	105 lb.	130 lb.	---	---
3010	18	157 lb.	201 lb.	---	---
4000	20	207 lb.	262 lb.	---	---

C<sub>v</sub> values assume Schedule 40 pipe. Valve weights are approximate. See page 49 for Flow Formulae.

## HOW TO ORDER CHECK-ALL STYLE F1, F6, FP

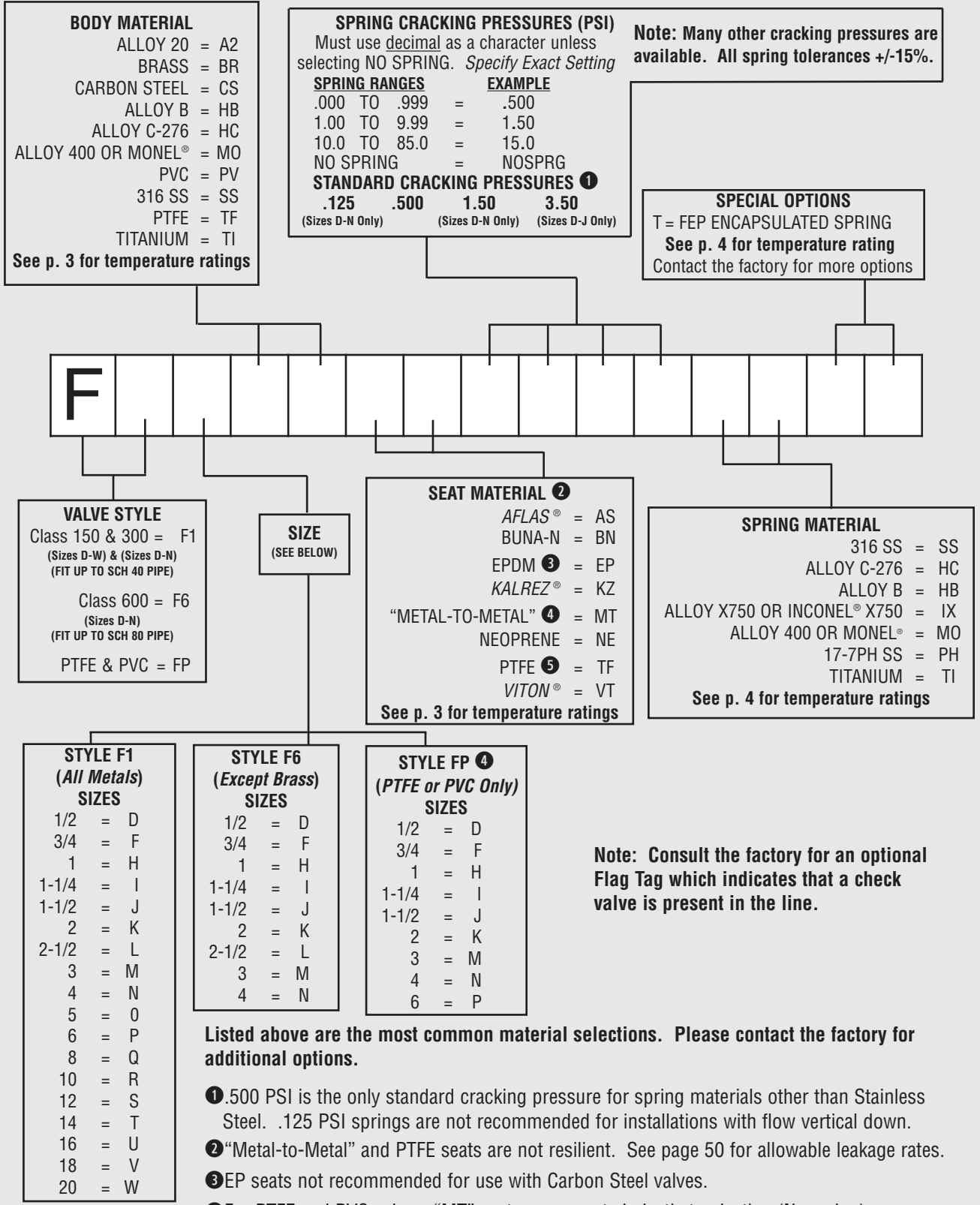

**BODY MATERIAL**  
 ALLOY 20 = A2  
 BRASS = BR  
 CARBON STEEL = CS  
 ALLOY B = HB  
 ALLOY C-276 = HC  
 ALLOY 400 OR MONEL® = MO  
 PVC = PV  
 316 SS = SS  
 PTFE = TF  
 TITANIUM = TI  
**See p. 3 for temperature ratings**

**SPRING CRACKING PRESSURES (PSI)**  
 Must use decimal as a character unless selecting NO SPRING. *Specify Exact Setting*  
**SPRING RANGES**      **EXAMPLE**  
 .000 TO .999 = .500  
 1.00 TO 9.99 = 1.50  
 10.0 TO 85.0 = 15.0  
 NO SPRING = NOSPRG  
**STANDARD CRACKING PRESSURES ①**  
 .125    .500    1.50    3.50  
 (Sizes D-N Only)    (Sizes D-N Only)    (Sizes D-J Only)

**Note: Many other cracking pressures are available. All spring tolerances +/-15%.**

**SPECIAL OPTIONS**  
 T = FEP ENCAPSULATED SPRING  
**See p. 4 for temperature rating**  
 Contact the factory for more options

**VALVE STYLE**  
 Class 150 & 300 = F1  
 (Sizes D-W) & (Sizes D-N)  
 (FIT UP TO SCH 40 PIPE)  
 Class 600 = F6  
 (Sizes D-N)  
 (FIT UP TO SCH 80 PIPE)  
 PTFE & PVC = FP

**SIZE**  
 (SEE BELOW)

**SEAT MATERIAL ②**  
 AFLAS® = AS  
 BUNA-N = BN  
 EPDM ③ = EP  
 KALREZ® = KZ  
 “METAL-TO-METAL” ④ = MT  
 NEOPRENE = NE  
 PTFE ⑤ = TF  
 VITON® = VT  
**See p. 3 for temperature ratings**

**SPRING MATERIAL**  
 316 SS = SS  
 ALLOY C-276 = HC  
 ALLOY B = HB  
 ALLOY X750 OR INCONEL® X750 = IX  
 ALLOY 400 OR MONEL® = MO  
 17-7PH SS = PH  
 TITANIUM = TI  
**See p. 4 for temperature ratings**

**STYLE F1**  
 (All Metals)  
**SIZES**  
 1/2 = D  
 3/4 = F  
 1 = H  
 1-1/4 = I  
 1-1/2 = J  
 2 = K  
 2-1/2 = L  
 3 = M  
 4 = N  
 5 = O  
 6 = P  
 8 = Q  
 10 = R  
 12 = S  
 14 = T  
 16 = U  
 18 = V  
 20 = W

**STYLE F6**  
 (Except Brass)  
**SIZES**  
 1/2 = D  
 3/4 = F  
 1 = H  
 1-1/4 = I  
 1-1/2 = J  
 2 = K  
 2-1/2 = L  
 3 = M  
 4 = N

**STYLE FP ④**  
 (PTFE or PVC Only)  
**SIZES**  
 1/2 = D  
 3/4 = F  
 1 = H  
 1-1/4 = I  
 1-1/2 = J  
 2 = K  
 3 = M  
 4 = N  
 6 = P

**Note: Consult the factory for an optional Flag Tag which indicates that a check valve is present in the line.**

**Listed above are the most common material selections. Please contact the factory for additional options.**

- ① .500 PSI is the only standard cracking pressure for spring materials other than Stainless Steel. .125 PSI springs are not recommended for installations with flow vertical down.
- ② “Metal-to-Metal” and PTFE seats are not resilient. See page 50 for allowable leakage rates.
- ③ EP seats not recommended for use with Carbon Steel valves.
- ④ For PTFE and PVC valves, “MT” seats mean seated plastic to plastic. (No o-ring)
- ⑤ “TF” seat not available for FP valve style.

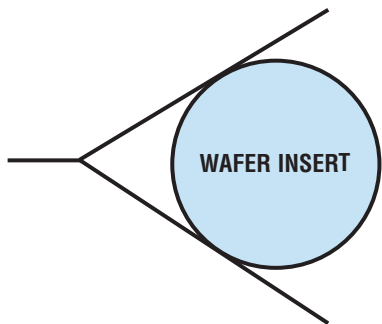

The **Wafer Insert (WV)** valve is designed to fit between two mating ANSI flanges. Two gaskets are required, instead of the one normally used in a flanged joint. The “drop in” valve body fits inside the bolt circle for quick installation and removal in rigid piping applications where the use of the F1, F6, or FP (see our **Flange Insert series on page 5**) is not practical. Many valves in this series can meet API 594 and/or B16.34 requirements. Consult the factory for more information.

The Wafer Insert valve can also be used as a low pressure relief valve or vacuum breaker by using the desired spring settings.

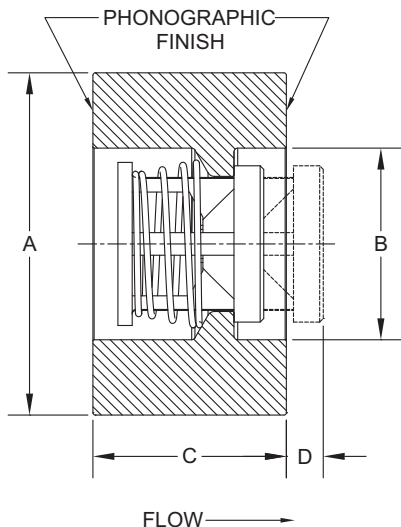

Nom. Pipe Size	Size Code	A	B	C	D ①	Orifice Diameter
1/2	D	1-3/8	0.62	1.38	N/A	0.348
3/4	F	1-3/4	0.82	1.38	N/A	0.464
1	H	2	1.05	1.38	0.35	0.593
1-1/4	I	2-1/2	1.38	1.63	0.27	0.890
1-1/2	J	2-7/8	1.61	1.63	0.54	1.135
2	K	3-5/8	2.07	2.38	0.17	1.385
2-1/2	L	4-1/8	2.47	2.62	0.31	1.555
3	M	5	3.07	2.88	0.42	2.025
4	N	6-3/16	4.03	2.88	1.25	2.560

① Maximum nominal dimension for a fully open valve with no spring.

Body Material ②	Nominal Pipe Size	Non-Shock Pressure-Temperature Rating
316 Stainless Steel (SS) Carbon Steel (CS) Alloy 20 (A2) Alloy C-276 (HC) Alloy B (HB) Alloy 400 or Monel® (MO) Titanium (TI)	1/2" - 2-1/2"	ANSI Class 150 - 1500 (1500 PSIG for o-ring seats)
	3"	ANSI Class 150 - 900 (1500 PSIG for o-ring seats)
	4"	ANSI Class 150 - 600
Brass (BR)	1/2" - 4"	ANSI Class 150 - 300

② See page 54 for material grade information.

**Wafer Insert**  
For Water at 72°F

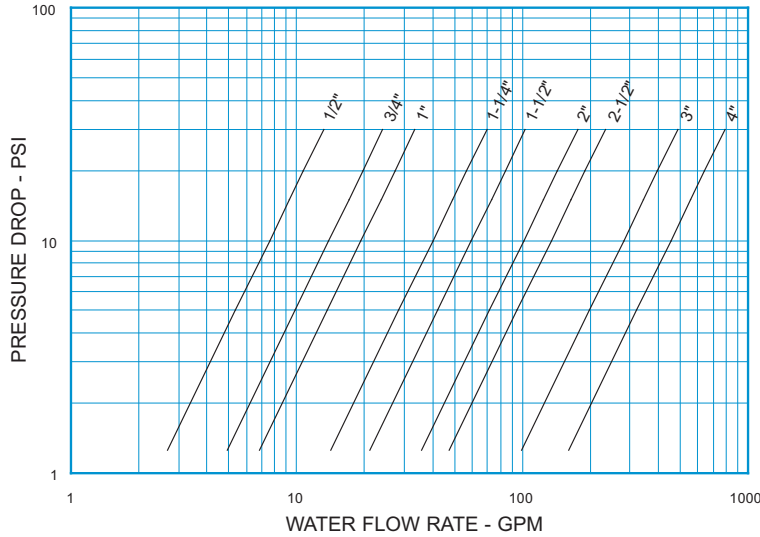

**Note:** All flow curves and Cv values presume the valves are fully open with 1/2 PSI cracking pressure springs. Consult the factory for more information.

STYLE WV C <sub>v</sub> VALUES & VALVE WEIGHTS			
C <sub>v</sub>	SIZE	SS & CS ALLOYS	BRASS
2.4	1/2	9.5 oz.	10.2 oz.
4.4	3/4	12.6 oz.	13.5 oz.
6.1	1	1.0 lb.	1.1 lb.
12.7	1-1/4	1.8 lb.	1.9 lb.
18.8	1-1/2	2.4 lb.	2.5 lb.
32.0	2	5.2 lb.	5.6 lb.
42.5	2-1/2	7.2 lb.	7.7 lb.
89.0	3	11.4 lb.	12.4 lb.
144	4	17.2 lb.	18.4 lb.

See page 49 for Flow Formulae.  
Valve weights are approximate.

**HOW TO ORDER  
CHECK-ALL STYLE WV**

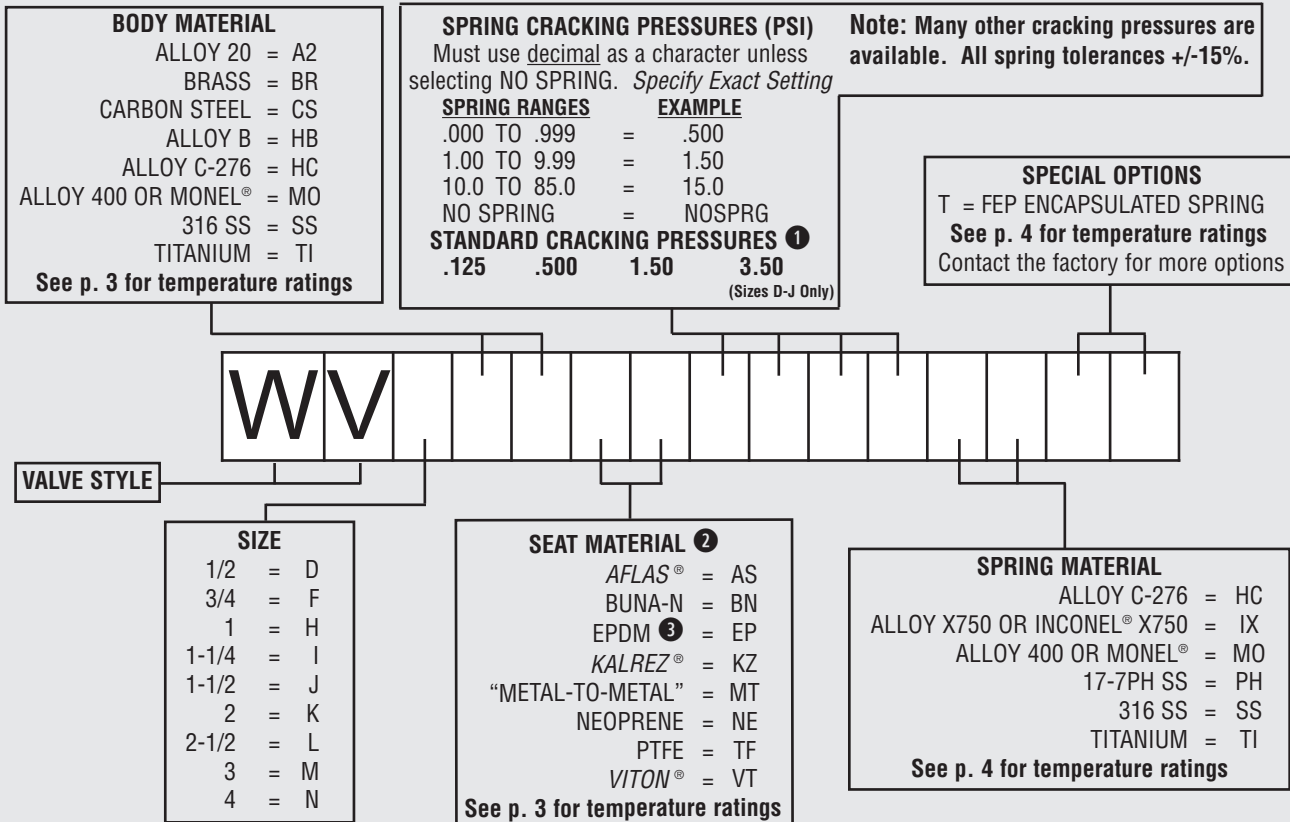

Listed above are the most common material selections. Please contact the factory for additional options.

- ① .500 PSI is the only standard cracking pressure for spring materials other than Stainless Steel. .125 PSI springs are not recommended for installations with flow vertical down.
- ② Seat materials other than “metal-to-metal” have a maximum pressure rating of 1500 PSI. “Metal-to-Metal” and PTFE seats are not resilient. See page 50 for allowable leakage rates.
- ③ EP seats not recommended for use with Carbon Steel valves.



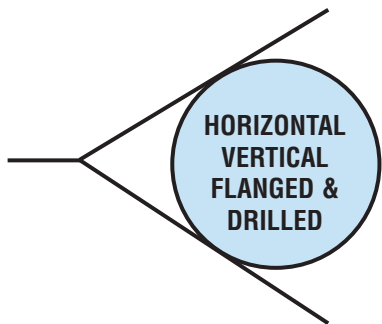

The **Check-All® Flanged & Drilled (HV)** check valve is a one piece cast body valve with ASME/ANSI B16.5 Class 150 flanged ends. The HV series valve is used when higher flow rates and lower pressure drops are required. The valve is available in sizes 1 inch through 10 inches and standard materials of CF8M (cast 316 stainless) and WCB/WCC (cast carbon steel). The HV series valve is designed for use with mating ANSI Class 150 flanges. Other materials are available upon request.

The HV valve can also be used as a low pressure relief valve or vacuum breaker by using the desired spring settings.

**NOTE:** Many valves in this series can be supplied with B16.34 certification. Consult the factory for more information.

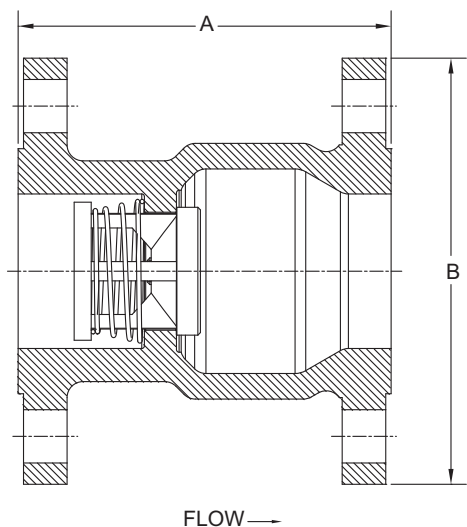

Nom. Pipe Size	Size Code	A	B	Orifice Diameter
1	H	3.75	4-1/4	0.890
1-1/4	I	3.80	4-5/8	1.135
1-1/2	J	4.38	5	1.385
2	K	5.13	6	2.025
2-1/2	L	7.28	7	2.560
3	M	8.38	7-1/2	3.280
4	N	9.69	9	3.875
6	P	13.75	11	6.380
8	Q	15.10	13-1/2	7.670
10	R	19.25	16	9.650

Cast Body Material ①	Availability	Non-Shock Pressure-Temperature Rating
CF8M Stainless Steel (SS)	Standard	ASME/ANSI B16.5 Class 150
WCB/WCC Carbon Steel (CS)		

① See page 54 for material grade information.

**Horizontal Vertical Flanged & Drilled**  
For Water at 72°F

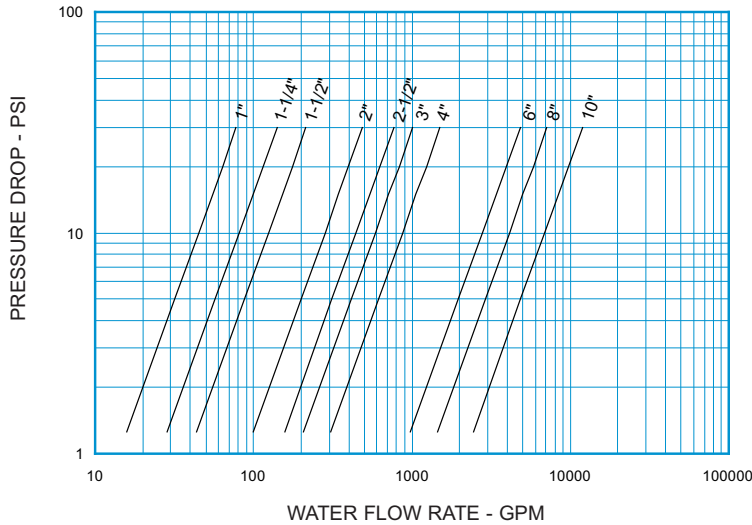

**Note:** All flow curves and Cv values presume the valves are fully open with 1/2 PSI cracking pressure springs. Consult the factory for more information.

STYLE HV C <sub>v</sub> VALUES & VALVE WEIGHTS		
C <sub>v</sub>	SIZE	SS & CS ALLOYS
14.2	1	4.3 lb.
25.6	1-1/4	5.3 lb.
39.2	1-1/2	7.8 lb.
91.9	2	11.5 lb.
140	2-1/2	20.7 lb.
275	3	25.9 lb.
333	4	44 lb.
878	6	88 lb.
1375	8	153 lb.
2175	10	263 lb.

See page 49 for Flow Formulae.  
Valve weights are approximate.

**HOW TO ORDER  
CHECK-ALL STYLE HV**

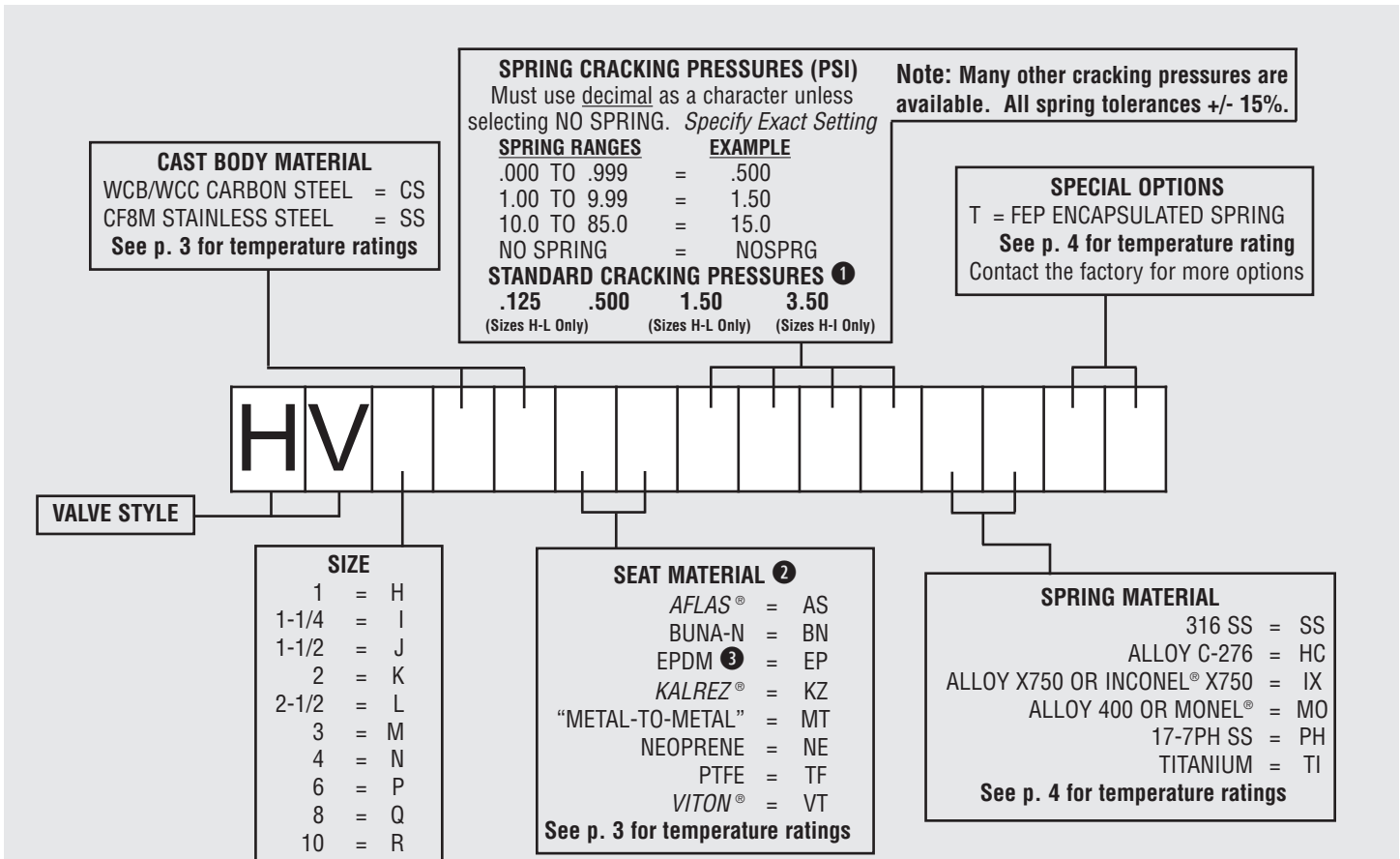

Listed above are the most common material selections. Please contact the factory for additional options.

- ① .500 PSI is the only standard cracking pressure for spring materials other than Stainless Steel. .125 PSI springs are not recommended for installations with flow vertical down.
- ② "Metal-to-Metal" and PTFE seats are not resilient. See page 50 for allowable leakage rates.
- ③ EP seats not recommended for use with Carbon Steel valves.

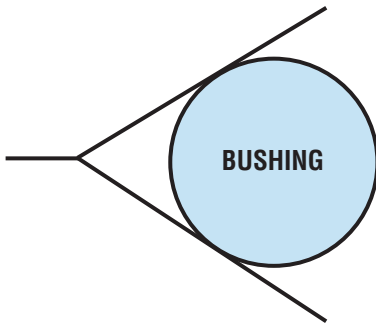

The **Bushing (BU, BR)** valve is a check valve with a standard bushing housing. The valve is adaptable to many types of service applications. It has very little restriction and produces a low pressure drop. It can be used quite effectively in systems where flow and pressure drop are critical by the use of a reducer coupling. The BU valve can also be used as a low pressure relief valve or vacuum breaker by using the desired spring settings.

The bushing thread sizes are designated by two sets of numbers; the first being the male thread, the second the female thread. NPT threads are per ASME B1.20.1. Also available with ISO 7 "R" (R male x Rp female) threads (BR).

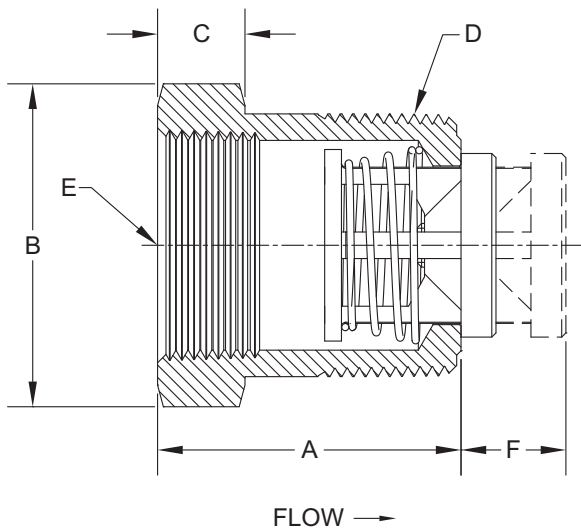

Nom. Pipe Size	Size Code	A	Hex <sup>1</sup> Size B	C	D	E	F <sup>2</sup>	Orifice Dia.
1/2 x 3/8	D	1.30	7/8	1/4	1/2 NPT	3/8 NPT	0.53	0.348
3/4 x 1/2	F	1.30	1-1/8	1/4	3/4 NPT	1/2 NPT	0.61	0.464
1 x 3/4	H	1.83	1-3/8	1/2	1 NPT	3/4 NPT	0.78	0.593
1-1/4 x 1	I	1.83	1-3/4	1/2	1-1/4 NPT	1 NPT	0.85	0.890
1-1/2 x 1-1/4	J	2.17	2	5/8	1-1/2 NPT	1-1/4 NPT	1.01	1.135
2 x 1-1/2	K	2.17	2-1/2	5/8	2 NPT	1-1/2 NPT	1.19	1.385
2-1/2 x 2	L	2.53	3	5/8	2-1/2 NPT	2 NPT	1.43	1.555
3 x 2-1/2	M	3.09	3-1/2	1	3 NPT	2-1/2 NPT	1.59	2.025

<sup>1</sup>May be larger and/or round.

<sup>2</sup>Maximum nominal dimension for a fully open valve with no spring.

Body Material <sup>3</sup>	Availability	Non-Shock Pressure-Temperature Rating
316 Stainless Steel (SS)	Standard	3000 PSIG @ 100°F (1500 PSIG for o-ring seats)
Carbon Steel (CS)		
Brass (BR)		
Alloy 20 (A2)	Semi-standard	
Alloy C-276 (HC)		
Alloy 400 or Monel® (MO)		
Alloy B (HB)	Contact the factory for these or other materials	
Titanium (TI)		

<sup>3</sup>See page 53 for material grade information.

**Bushing**  
For Water at 72°F

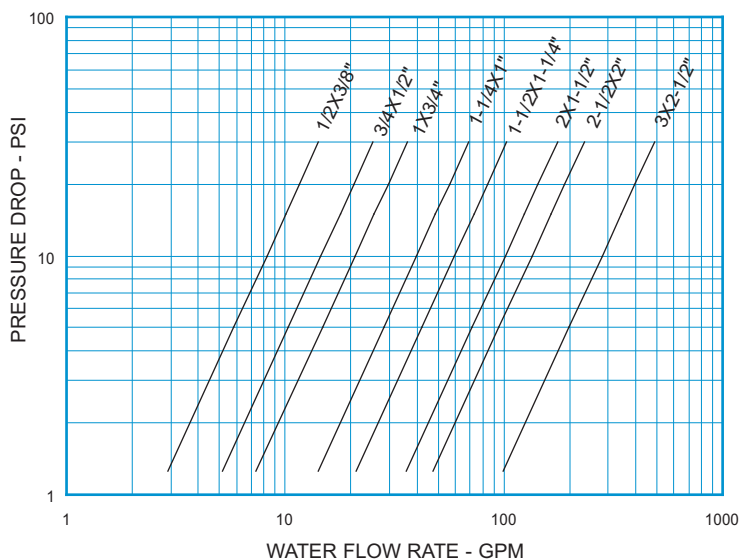

**Note:** All flow curves and Cv values presume the valves are fully open with 1/2 PSI cracking pressure springs. Consult the factory for more information.

STYLE BU C <sub>v</sub> VALUES & VALVE WEIGHTS		
C <sub>v</sub>	SIZE	ALL MATL
2.6	1/2 x 3/8	1.7 oz.
4.6	3/4 x 1/2	2.9 oz.
6.6	1 x 3/4	6.4 oz.
12.6	1-1/4 x 1	10.8 oz.
18.8	1-1/2 x 1-1/4	13.8 oz.
32.0	2 x 1-1/2	1.6 lb.
42.5	2-1/2 x 2	2.3 lb.
89.0	3 x 2-1/2	5.4 lb.

See page 49 for Flow Formulae.  
Valve weights are approximate.

**HOW TO ORDER  
CHECK-ALL STYLE BU**

**BODY MATERIAL**  
 ALLOY 20 = A2  
 BRASS = BR  
 CARBON STEEL = CS  
 ALLOY B = HB  
 ALLOY C-276 = HC  
 ALLOY 400 OR MONEL® = MO  
 316 SS = SS  
 TITANIUM = TI  
 See p. 3 for temperature ratings

**SPRING CRACKING PRESSURES (PSI)**  
 Must use decimal as a character unless selecting NO SPRING. *Specify Exact Setting*  
**SPRING RANGES**      **EXAMPLE**  
 .000 TO .999 = .500  
 1.00 TO 9.99 = 1.50  
 10.0 TO 85.0 = 15.0  
 NO SPRING = NOSPRG  
**STANDARD CRACKING PRESSURES ①**  
 .125    .500    1.50    3.50  
 (Sizes D-J Only)

**Note:** Many other cracking pressures are available. All spring tolerances +/- 15%.

**SPECIAL OPTIONS**  
 T = FEP ENCAPSULATED SPRING  
 See p. 4 for temperature ratings  
 Contact the factory for more options

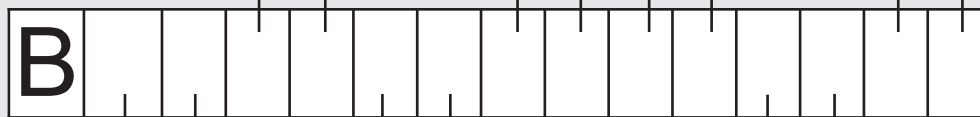

**VALVE STYLE**  
 NPT Threads = BU  
 ISO 7 R & Rp Threads = BR

**SIZE**  
 1/2 x 3/8 = D  
 3/4 x 1/2 = F  
 1 x 3/4 = H  
 1-1/4 x 1 = I  
 1-1/2 x 1-1/4 = J  
 2 x 1-1/2 = K  
 2-1/2 x 2 = L  
 3 x 2-1/2 = M

**SEAT MATERIAL ②**  
 AFLAS® = AS  
 BUNA-N = BN  
 EPDM ③ = EP  
 KALREZ® = KZ  
 "METAL-TO-METAL" = MT  
 NEOPRENE = NE  
 PTFE = TF  
 VITON® = VT  
 See p. 3 for temperature ratings

**SPRING MATERIAL**  
 ALLOY C-276 = HC  
 ALLOY X750 OR INCONEL® X750 = IX  
 ALLOY 400 OR MONEL® = MO  
 17-7PH SS = PH  
 316 SS = SS  
 TITANIUM = TI  
 See p. 4 for temperature ratings

Listed above are the most common material selections. Please contact the factory for additional options.

- ① .500 PSI is the only standard cracking pressure for spring materials other than Stainless Steel. .125 PSI springs are not recommended for installations with flow vertical down.
- ② Seat materials other than "metal-to-metal" have a maximum pressure rating of 1500 PSI. "Metal-to-Metal" and PTFE seats are not resilient. See page 50 for allowable leakage rates.
- ③ EP seats not recommended for use with Carbon Steel valves.

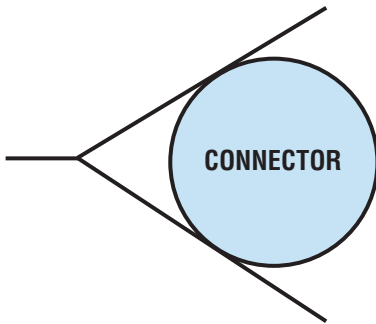

The **Connector (CN, CR)** valve is a check valve with a pipe nipple or connector housing. It is designed to be used in installations where a check valve with male pipe threads is required. The CN valve is adaptable for use as a low pressure relief valve or vacuum breaker by using the desired spring settings. Two valves used in combination make an excellent pressure vacuum vent. NPT threads are per ASME B1.20.1. Also available with ISO 7 “R” threads (CR).

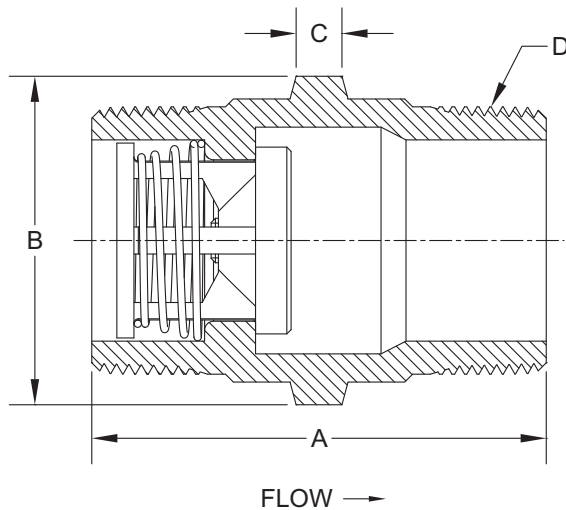

Nom. Pipe Size	Size Code	A	Hex <sup>1</sup> Size B	C	D	Orifice Diameter
1/2	D	2.34	7/8	0.28	1/2 NPT	0.348
3/4	F	2.34	1-1/8	0.27	3/4 NPT	0.464
1	H	3.00	1-3/8	0.35	1 NPT	0.593
1-1/4	I	3.00	1-3/4	0.33	1-1/4 NPT	0.890
1-1/2	J	3.19	2	0.32	1-1/2 NPT	1.135
2	K	3.68	2-1/2	N/A	2 NPT	1.385
2-1/2	L	5.00	3-1/4	N/A	2-1/2 NPT	1.555
3	M	5.50	4	N/A	3 NPT	2.025
4	N	5.00	4-1/2	N/A	4 NPT	2.560

<sup>1</sup>May be larger and/or round.

Body Material <sup>2</sup>	Availability	Non-Shock Pressure-Temperature Rating	
316 Stainless Steel (SS)	Standard	1/2" - 3" 3000 PSIG @ 100°F (1500 PSIG for o-ring seats)	4" 1500 PSIG @ 100°F
Carbon Steel (CS)			
Brass (BR)			
Alloy 20 (A2)	Semi-standard		
Alloy C-276 (HC)			
Alloy 400 or Monel <sup>®</sup> (MO)			
Alloy B (HB)	Contact the factory for these or other materials		
Titanium (TI)			

<sup>2</sup>See page 53 for material grade information.



**Note:** All flow curves and Cv values presume the valves are fully open with 1/2 PSI cracking pressure springs. Consult the factory for more information.

**Connector**  
For Water at 72°F

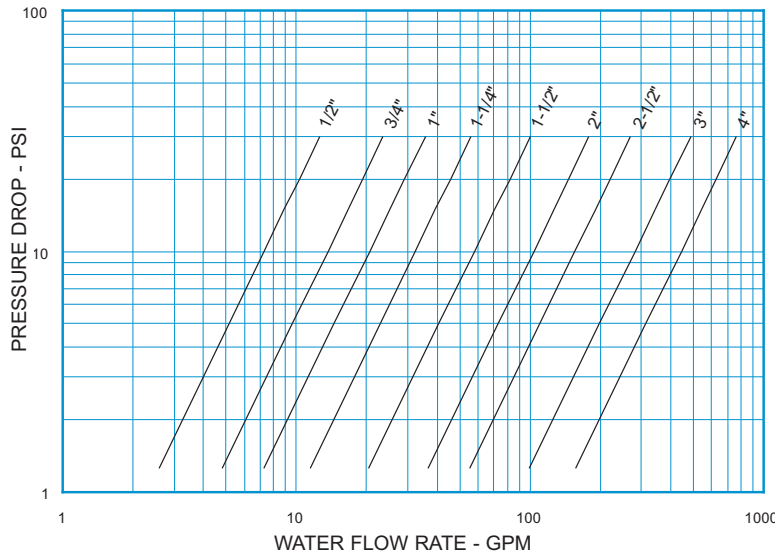

STYLE CN C <sub>v</sub> VALUES & VALVE WEIGHTS		
C <sub>v</sub>	SIZE	ALL MATL
2.3	1/2	2.5 oz.
4.3	3/4	3.9 oz.
6.5	1	7.5 oz.
10.2	1-1/4	10.9 oz.
18.3	1-1/2	1.5 lb.
32.7	2	2.7 lb.
49.2	2-1/2	5.0 lb.
89.0	3	8.9 lb.
140	4	11.1 lb.

See page 49 for Flow Formulae.  
Valve weights are approximate.

**HOW TO ORDER  
CHECK-ALL STYLE CN**

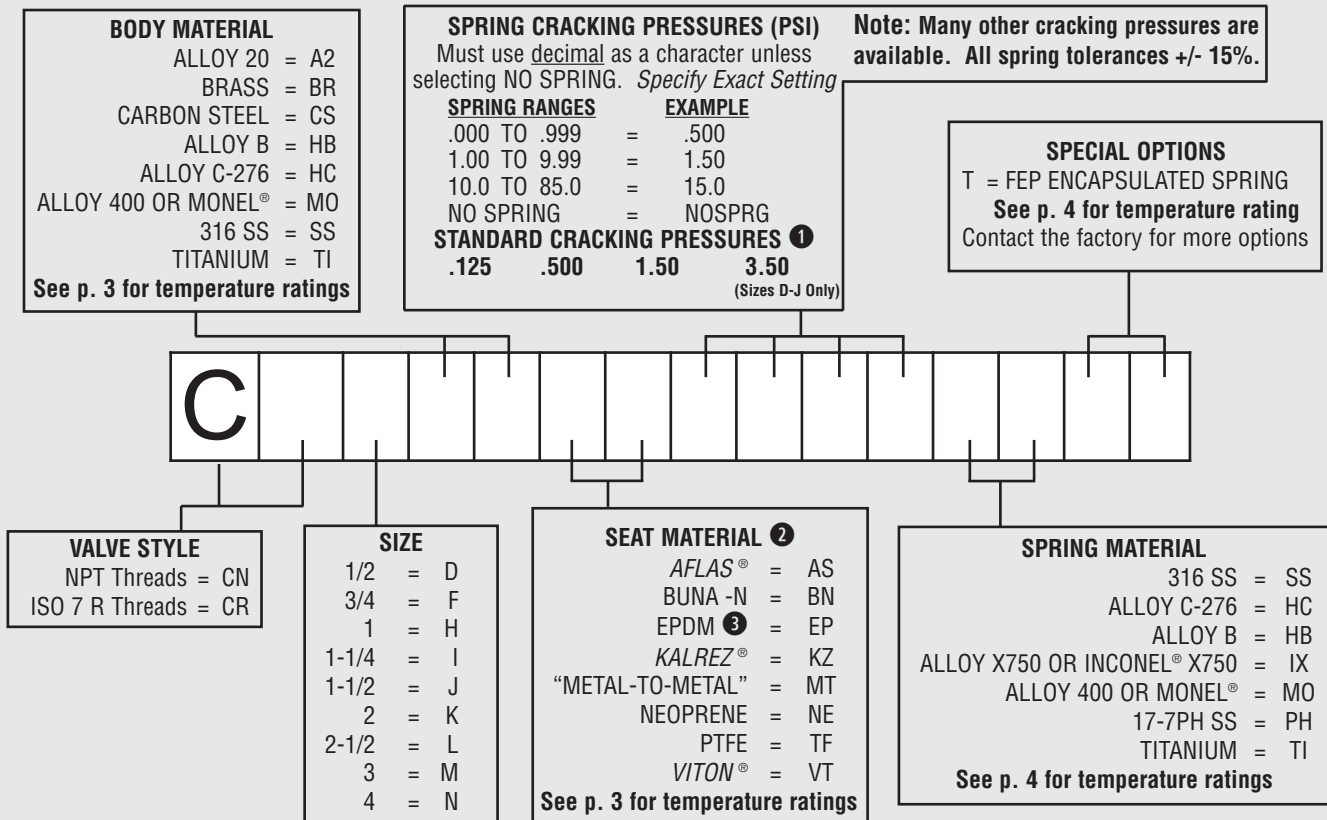

Listed above are the most common material selections. Please contact the factory for additional options.

- ① .500 PSI is the only standard cracking pressure for spring materials other than Stainless Steel. .125 PSI springs are not recommended for installations with flow vertical down.
- ② Seat materials other than "metal-to-metal" have a maximum pressure rating of 1500 PSI. "Metal-to-Metal" and PTFE seats are not resilient. See page 50 for allowable leakage rates.
- ③ EP seats not recommended for use with Carbon Steel valves.

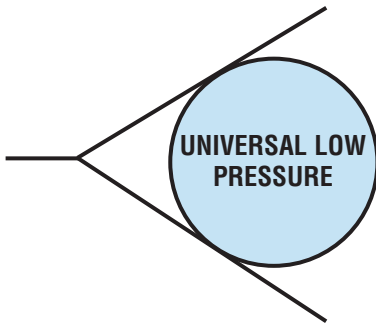

The **Universal Low Pressure (U3, UR)** check valve is a one piece body machined from bar stock and is designed for minimum pressure drop. The valve has a light-weight, compact design that provides maintenance-free, dependable service. NPT threads are per ASME B1.20.1. Also available with ISO 7 “Rp” threads. (UR). These valves can also be used as a low pressure relief valve or vacuum breaker by using the desired spring settings.

**NOTE:** Many valves in this series can be supplied with B16.34 certification. Consult the factory for more information.

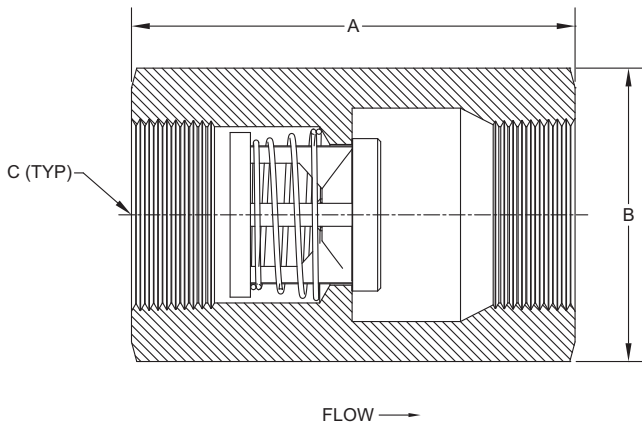

Nom. Pipe Size	Size Code	A	Hex <sup>1</sup> Size B	C	Orifice Diameter
3/8	C	2.16	13/16	3/8 NPT	0.348
1/2	D	2.71	1-1/8	1/2 NPT	0.464
3/4	F	2.95	1-1/4	3/4 NPT	0.593
1	H	3.64	1-5/8	1 NPT	0.890
1-1/4	I	3.91	2-1/4	1-1/4 NPT	1.135
1-1/2	J	4.36	2-1/2	1-1/2 NPT	1.385
2	K	5.85	3	2 NPT	1.555
2-1/2	L	5.50	3-3/4	2-1/2 NPT	1.555
3	M	6.25	4-1/2	3 NPT	2.025
4	N	7.13	5-1/2	4 NPT	2.560

<sup>1</sup> May be larger and/or round.

Body Material <sup>2</sup>	Availability	Non-Shock Pressure-Temperature Rating	
316 Stainless Steel (SS)	Standard	3/8" - 3"	4"
Carbon Steel (CS)			
Brass (BR)			
Alloy 20 (A2)	Semi-standard	3000 PSIG @ 100°F (1500 PSIG for o-ring seats)	1500 PSIG @ 100°F
Alloy C-276 (HC)			
Alloy 400 or Monel <sup>®</sup> (MO)	Contact the factory for these or other materials		
Alloy B (HB)			
Titanium (TI)			

<sup>2</sup> See page 54 for material grade information.

**Universal Low Pressure**  
For Water at 72°F

**Note:** All flow curves and Cv values presume the valves are fully open with 1/2 PSI cracking pressure springs. Consult the factory for more information.

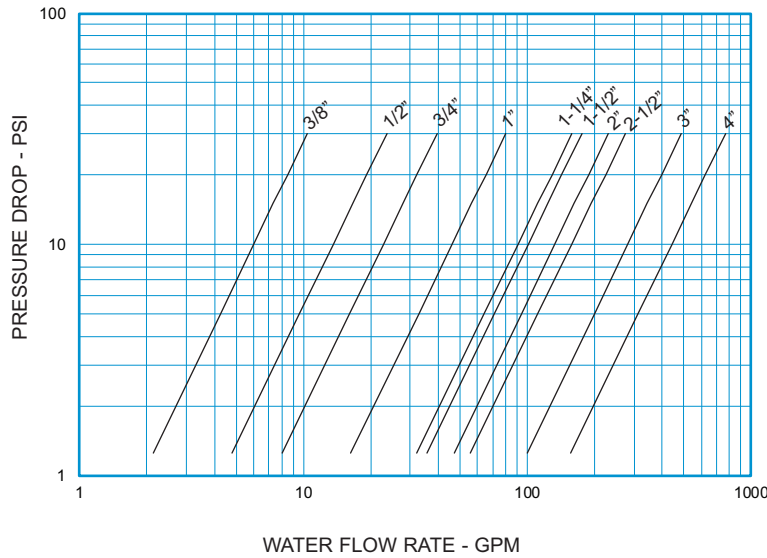

STYLE U3 C <sub>v</sub> VALUES & VALVE WEIGHTS			
C <sub>v</sub>	SIZE	SS & CS ALLOYS	BRASS
1.9	3/8	3.0 oz.	3.3 oz.
4.3	1/2	8.5 oz.	9.1 oz.
7.2	3/4	9.6 oz.	10.1 oz.
14.6	1	1.2 lb.	1.3 lb.
28.8	1-1/4	2.9 lb.	3.2 lb.
31.9	1-1/2	3.6 lb.	3.9 lb.
42.0	2	6.5 lb.	7.2 lb.
50.0	2-1/2	9.2 lb.	10 lb.
89.0	3	14.3 lb.	15.5 lb.
140	4	21.7 lb.	23.9 lb.

See page 49 for Flow Formulae.  
Valve weights are approximate.

**HOW TO ORDER  
CHECK-ALL STYLE U3**

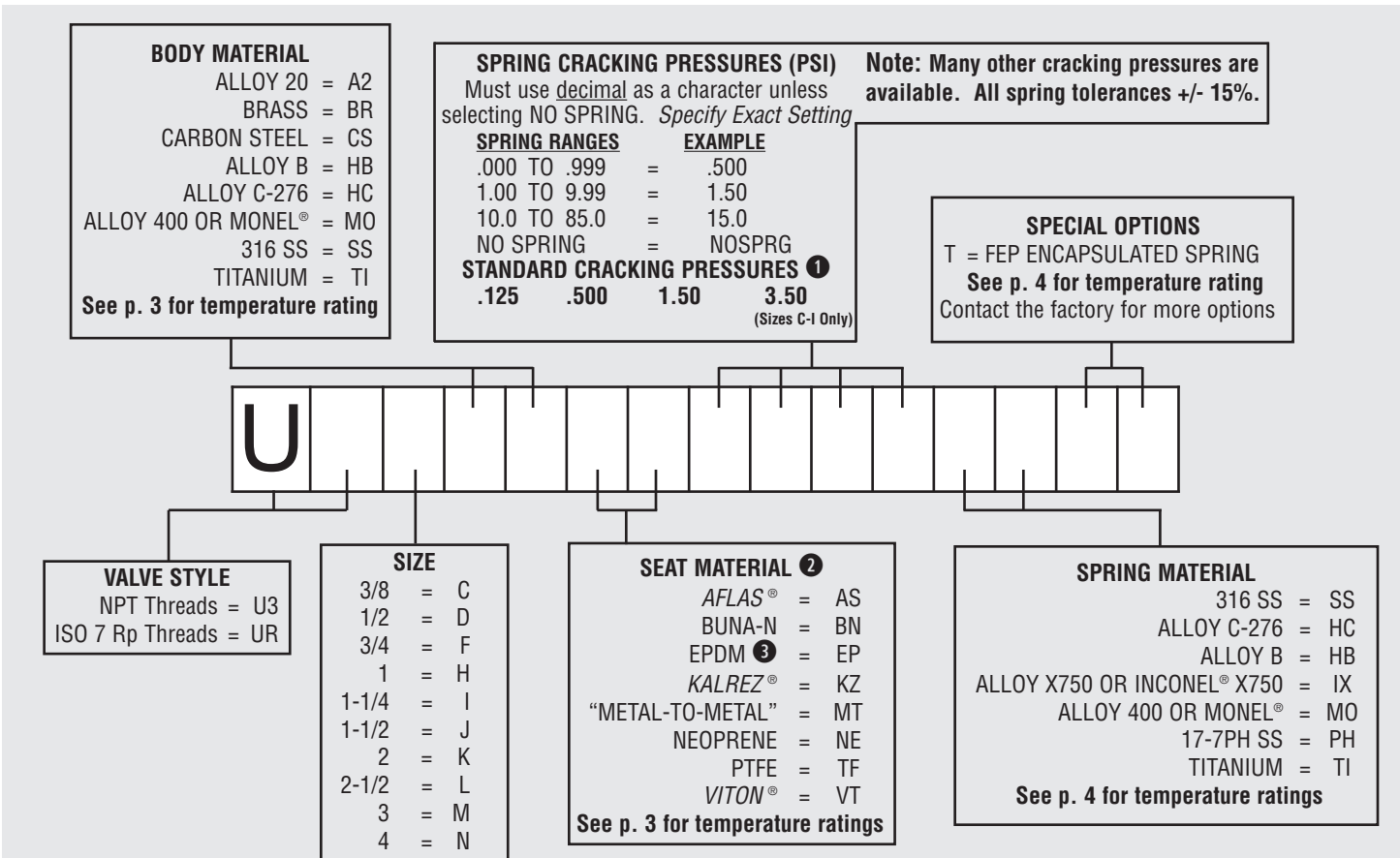

Listed above are the most common material selections. Please contact the factory for additional options.

- ① .500 PSI is the only standard cracking pressure for spring materials other than Stainless Steel. .125 PSI springs are not recommended for installations with flow vertical down.
- ② Seat materials other than “metal-to-metal” have a maximum pressure rating of 1500 PSI. “Metal-to-Metal” and PTFE seats are not resilient. See page 50 for allowable leakage rates.
- ③ EP seats not recommended for use with Carbon Steel valves.

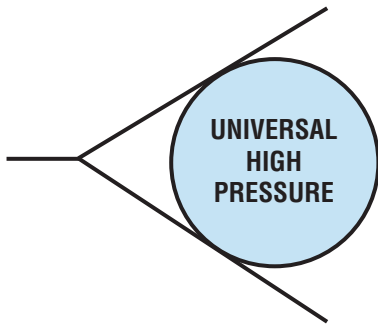

The **Universal High Pressure (U1, R1)** check valve is a one piece body machined from bar stock with female pipe threads. The valve is designed and manufactured for high pressure applications. These valves can also be used as low pressure relief valves or vacuum breakers by using the desired spring settings. This valve is normally supplied with a “metal-to-metal” seat. NPT threads are per ASME B1.20.1. Also available with ISO 7 “Rp” threads. (R1).

**NOTE:** Many valves in this series can be supplied with B16.34 certification. Consult the factory for more information.

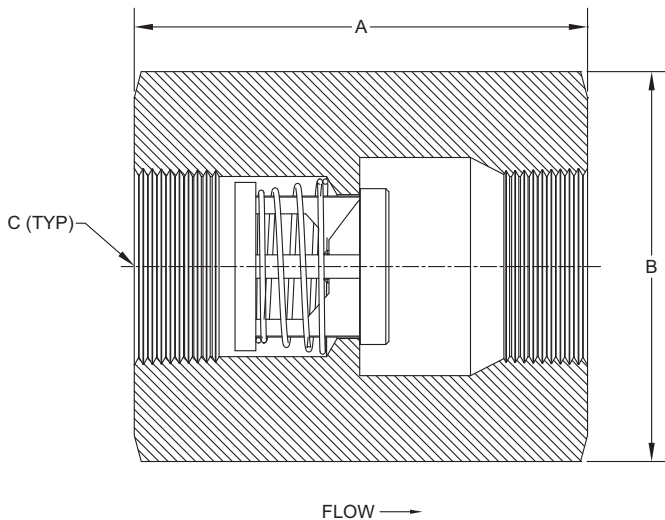

Nom. Pipe Size	Size Code	A	Hex <sup>1</sup> Size B	C	Orifice Diameter
3/8	C	2.16	1	3/8 NPT	0.348
1/2	D	2.71	1-1/4	1/2 NPT	0.464
3/4	F	2.95	1-5/8	3/4 NPT	0.593
1	H	3.64	2-1/4	1 NPT	0.890
1-1/4	I	3.91	2-3/4	1-1/4 NPT	1.135
1-1/2	J	4.36	3-1/4	1-1/2 NPT	1.385

<sup>1</sup> May be larger and/or round.

Body Material <sup>2</sup>	Availability	Non-Shock Pressure-Temperature Rating
316 Stainless Steel (SS)	Standard	10,000 PSIG @ 100°F
Carbon Steel (CS)		
Alloy 20 (A2)		
Alloy C-276 (HC)	Semi-standard	
Alloy 400 or Monel <sup>®</sup> (MO)		
Alloy B (HB)	Contact the factory for these or other materials	
Titanium (TI)		

<sup>2</sup> See page 54 for material grade information.

**Universal High Pressure**  
For Water at 72°F

**Note:** All flow curves and Cv values presume the valves are fully open with 1/2 PSI cracking pressure springs. Consult the factory for more information.

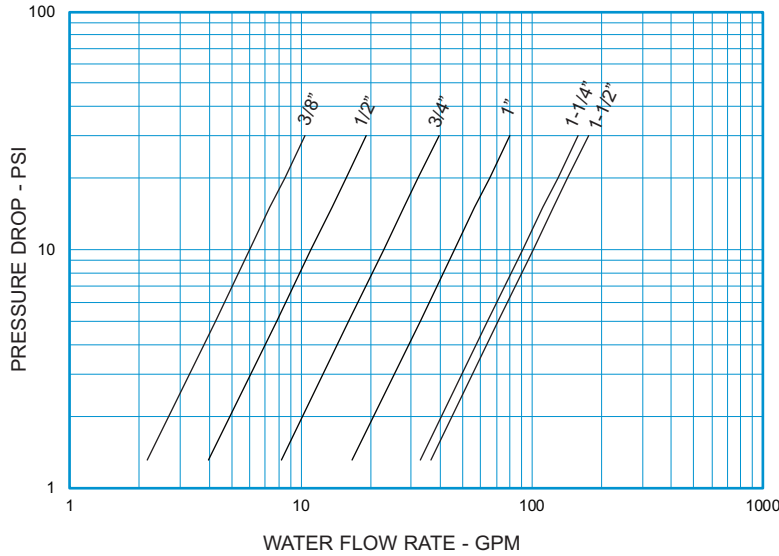

STYLE U1 C <sub>v</sub> VALUES & VALVE WEIGHTS		
C <sub>v</sub>	SIZE	SS & CS ALLOYS
1.9	3/8	5.9 oz.
3.5	1/2	11.8 oz.
7.2	3/4	1.4 lb.
14.6	1	3.5 lb.
28.8	1-1/4	5.4 lb.
31.9	1-1/2	8.1 lb.

See page 49 for Flow Formulae.  
Valve weights are approximate.

**HOW TO ORDER  
CHECK-ALL STYLE U1**

**BODY MATERIAL**

ALLOY 20 = A2  
CARBON STEEL = CS  
ALLOY B = HB  
ALLOY C-276 = HC  
ALLOY 400 OR MONEL® = MO  
316 SS = SS  
TITANIUM = TI

See p. 3 for temperature rating

**SPRING CRACKING PRESSURES (PSI)**  
Must use decimal as a character unless selecting NO SPRING. *Specify Exact Setting*

SPRING RANGES	EXAMPLE
.000 TO .999	= .500
1.00 TO 9.99	= 1.50
10.0 TO 85.0	= 15.0
NO SPRING	= NOSPRG

**STANDARD CRACKING PRESSURES ①**

.125	.500	1.50	3.50
------	------	------	------

(Sizes C-I Only)

**Note:** Many other cracking pressures are available. All spring tolerances +/- 15%.

**SPECIAL OPTIONS**

T = FEP ENCAPSULATED SPRING  
See p. 4 for temperature rating  
Contact the factory for more options

1					MT														
---	--	--	--	--	----	--	--	--	--	--	--	--	--	--	--	--	--	--	--

**VALVE STYLE**

NPT Threads = U1  
ISO 7 Rp Threads = R1

**SIZE**

3/8 = C  
1/2 = D  
3/4 = F  
1 = H  
1-1/4 = I  
1-1/2 = J

**SEAT MATERIAL ②**

“METAL-TO-METAL” = MT  
Same temperature rating as body

**SPRING MATERIAL**

316 SS = SS  
ALLOY C-276 = HC  
ALLOY B = HB  
ALLOY X750 OR INCONEL® X750 = IX  
ALLOY 400 OR MONEL® = MO  
17-7PH SS = PH  
TITANIUM = TI

See p. 4 for temperature ratings

**Listed above are the most common material selections. Please contact the factory for additional options.**

① .500 PSI is the only standard cracking pressure for spring materials other than Stainless Steel. .125 PSI springs are not recommended for installations with flow vertical down.

② “Metal-to-Metal” seats are not resilient. See page 50 for allowable leakage rates.





2104/68/EU  
COMPLIANT  
See page 55 for Details

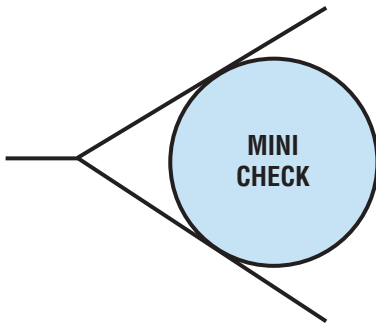

The **Mini-Check (M1 - M8)** is designed for minimum pressure drop. The three-piece construction permits many combinations of end fittings, which makes the valve adaptable for nearly every application. The Mini-Check is available with 1/8, 1/4, and 3/8 inch pipe threads, both male and female. It can also be supplied with a 1/8, 1/4, or 3/8 inch **tubing end** on one side and with a **pipe thread end** on the other. **Combinations** of male and female threads are also available. The Mini-Check can also be used as a low pressure relief valve or vacuum breaker by using the desired spring settings.

**NOTE:** Many valves in this series can be supplied with B16.34 certification. Consult the factory for more information.

- M1 – Male pipe threads both ends.
- M2 – Female pipe threads both ends.
- M3 – Male pipe **inlet** – female pipe **outlet**.
- M4 – Female pipe **inlet** – male pipe **outlet**.
- M5 – Male pipe **inlet** – tubing **outlet**.
- M6 – Female pipe **inlet** – tubing **outlet**.
- M7 – Tubing **inlet** – male pipe **outlet**.
- M8 – Tubing **inlet** – female pipe **outlet**.

**NOTE:** When ordering styles M5 through M8 be sure to specify whether **compression (-C)** or **37° flare (-F)**.

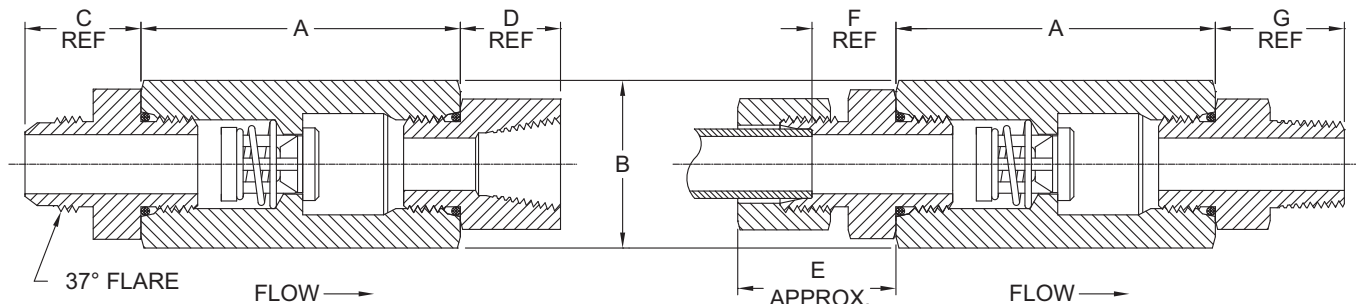

Nom. Pipe & Tube Size	Size Code	A	Hex Size B ①	C	D	E	F	G	Orifice Diameter
1/8	A	2.16	7/8	0.75	0.71	0.93	0.11	0.73	0.348
1/4	B	2.16	7/8	0.92	0.84	1.23	0.57	0.97	0.348
3/8	C	2.48	1-1/8	0.92	0.91	1.32	0.59	1.00	0.464

① May be larger and/or round.

Body Material ②	Non-Shock Pressure-Temperature Rating ③
316 Stainless Steel (SS)	5000 PSIG @ 100°F
Carbon Steel (CS)	
Brass (BR)	3000 PSIG @ 100°F

② See page 54 for material grade information.  
③ Maximum Pressure 1500 PSI for o-ring seats.

**Mini Check**  
For Water at 72°F

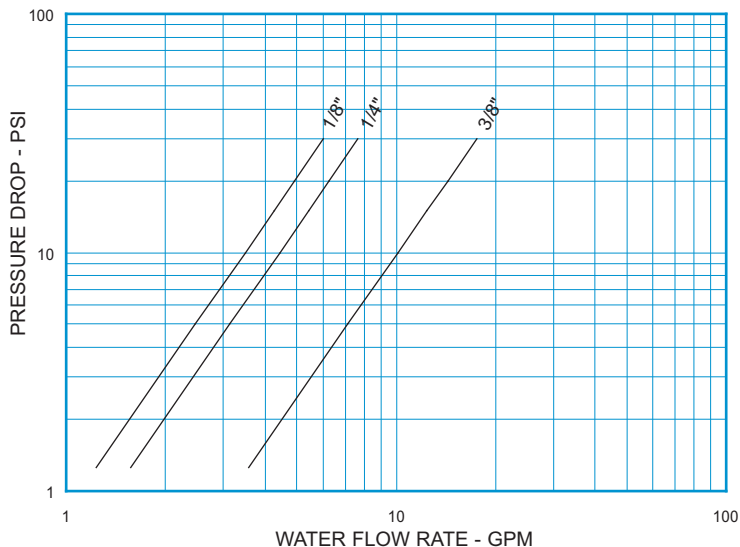

**Note:** All flow curves and Cv values presume the valves are fully open with 1/2 PSI cracking pressure springs. Consult the factory for more information.

STYLE M1-M8 C <sub>v</sub> VALUES & VALVE WEIGHTS		
C <sub>v</sub>	SIZE	ALL MATL
1.1	1/8	6.2 oz.
1.4	1/4	7.3 oz.
3.2	3/8	11.8 oz.

See page 49 for Flow Formulae.  
Valve weights are approximate.

## HOW TO ORDER CHECK-ALL STYLE M1 - M8

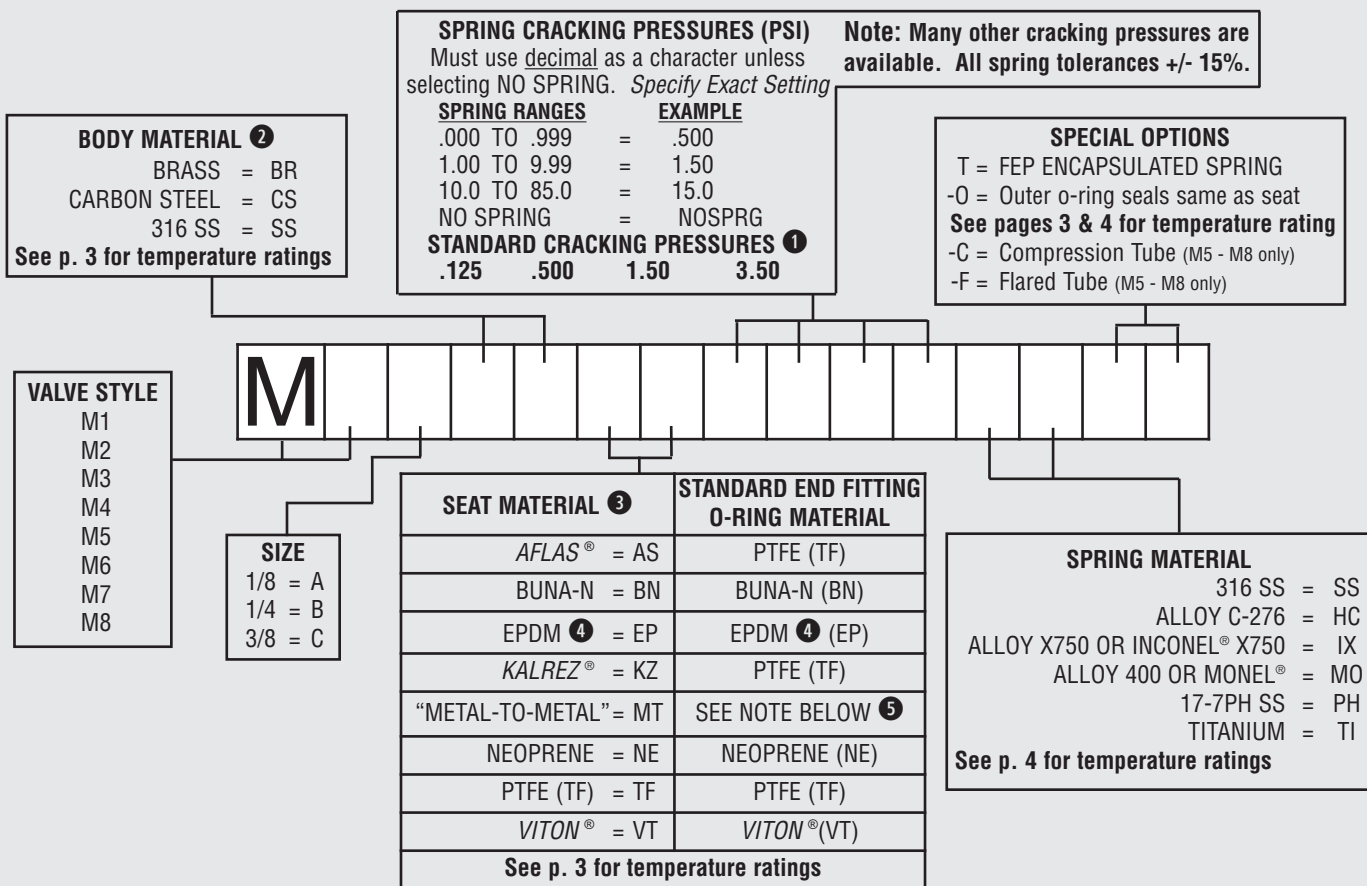

Listed above are the most common material selections. Please contact the factory for additional options.

- ① .500 PSI is the only standard cracking pressure for spring materials other than Stainless Steel. .125 PSI springs are not recommended for installations with flow vertical down.
- ② Brass valves have plated Carbon Steel tube fittings if applicable. Consult factory if other body or fitting materials are desired.
- ③ Seat materials other than "metal-to-metal" have a maximum pressure rating of 1500 PSI. "Metal-to-Metal" and PTFE seats are not resilient. See page 50 for allowable leakage rates.
- ④ EP seats not recommended for use with Carbon Steel valves.
- ⑤ Fitting o-rings are the same as the seat for standard seat materials. For "metal-to-metal" seated valves, end fitting o-rings are Buna-N for brass and carbon steel valves and Viton® for stainless steel valves.



See page 56  
Non-PED statement

Valve shown in ferrules.  
Ferrules and clamp not included.

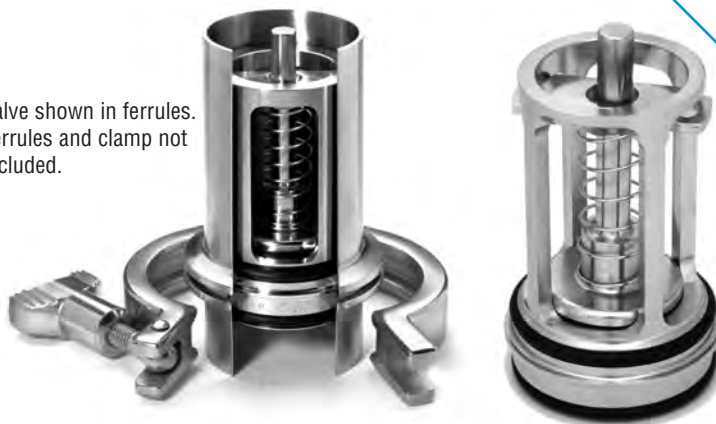
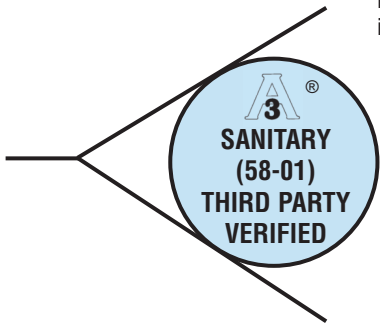

US Patent Numbers:  
6,039,073; 6,152,171

The **3-A SANITARY (3S)** valve is an electropolished 316/316L stainless steel check valve with a standard 32 Ra or better finish (consult the factory for finer finish availability) for use in new or existing sanitary systems. This valve's design seals on the ID of sanitary ferrules with 3-A specified materials. The valve seals inside fittings such as Alfa Laval Inc. Bevel Seat and Tri-Clamp®, Waukesha Cherry-Burrell® Q-Line and S-Line and others with ID dimensions equal to the "F" dimensions listed below (ferrules not included). This valve is designed to be easily disassembled and cleaned. Spare parts are also available. The compact design fits inside a single set of ferrules and requires no additional space in the line. The insert design makes it extremely economical when compared to full-bodied valves. The 3S valve can be used as a check valve or vacuum breaker. Please use "V" special option when ordering as a vacuum breaker. The standard spring material is 316 SS. Consult factory for additional options.

**Note: USP Class VI o-rings can be supplied with certification.**

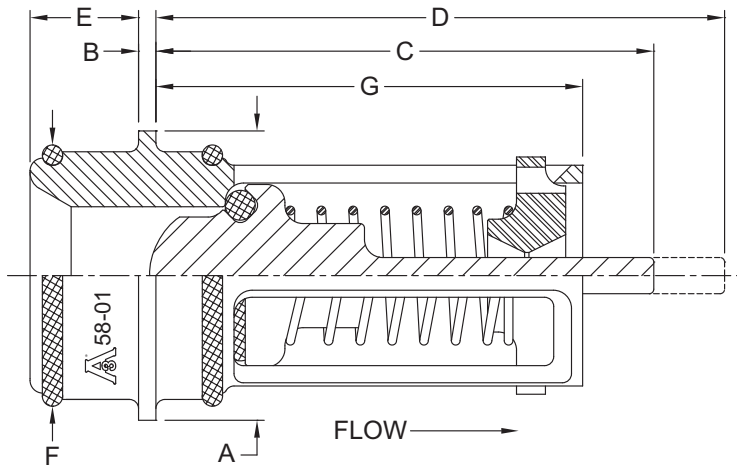

Line Size	Size Code	A	B	C ①	D ②	E	F ③	G	Orifice Diameter
1	H	1	1/16	1.72	2.16	0.38	0.870	1.47	0.476
1-1/2	J	1-1/2	1/16	2.53	3.47	0.38	1.370	2.18	0.890
2	K	2	1/16	3.03	4.13	0.47	1.870	2.59	1.135
2-1/2	L	2-1/2	1/16	3.28	4.59	0.47	2.370	2.85	1.595
3	M	3	1/16	4.59	5.53	0.47	2.870	3.36	2.150
4	N	4	1/16	4.75	6.69	0.47	3.834	4.02	2.699

- ① Maximum nominal dimension for valve closed.
- ② Maximum nominal dimension for a fully open valve.
- ③ Valves are designed to function with fittings having these internal diameters.(±0.005)

Body Material ④	Line Size	Non-Shock Pressure-Temperature Rating ⑤
316/316L Stainless Steel (SS)	1"	1000 PSIG @ 100°F
	1-1/2" - 4"	725 PSIG @ 100°F

- ④ See page 53 for material grade information.
- ⑤ Consult the factory for applications where higher pressure or temperature is expected.

**Note:** 30 PSI is the maximum recommended pressure drop.

## Disassembly For Cleaning Instructions

To disassemble the 3-A Sanitary valve, start by depressing one side of the retainer as shown in Step 1. With one side of the retainer tipped, rotate the stem of the poppet and remove the retainer as shown in Steps 2, 3 and 4. To reassemble the valve reverse the process. Consult the factory for information on trim kits, o-ring kits, or individual spare parts.

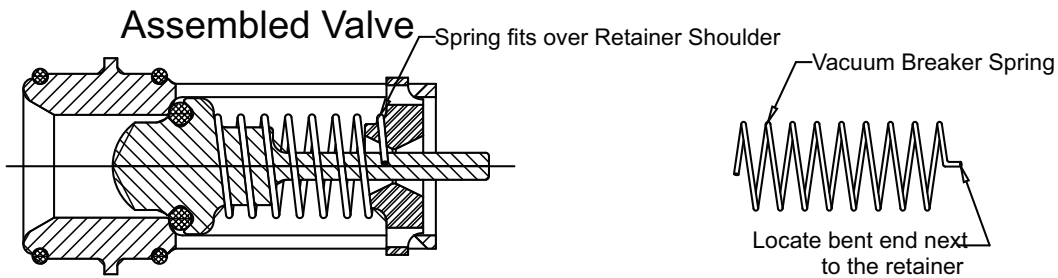
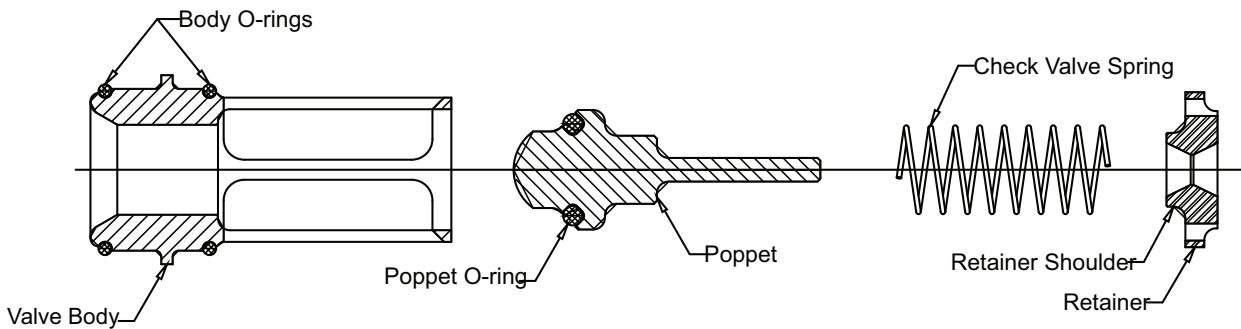

Step 1

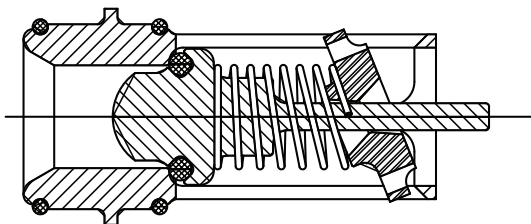

Step 2

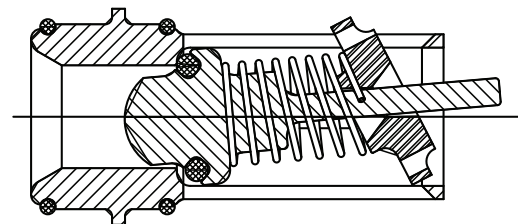

Step 3

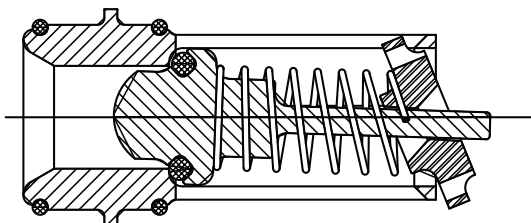

Step 4

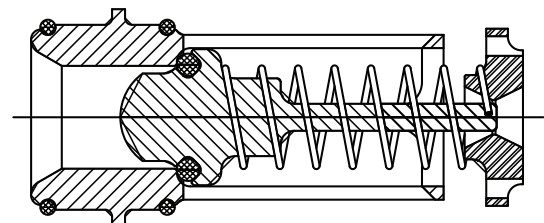

**3-A Sanitary**  
For Water at 72°F

**Note:** All flow curves and Cv values presume the valves are fully open with 1/2 PSI cracking pressure springs. Consult the factory for more information.

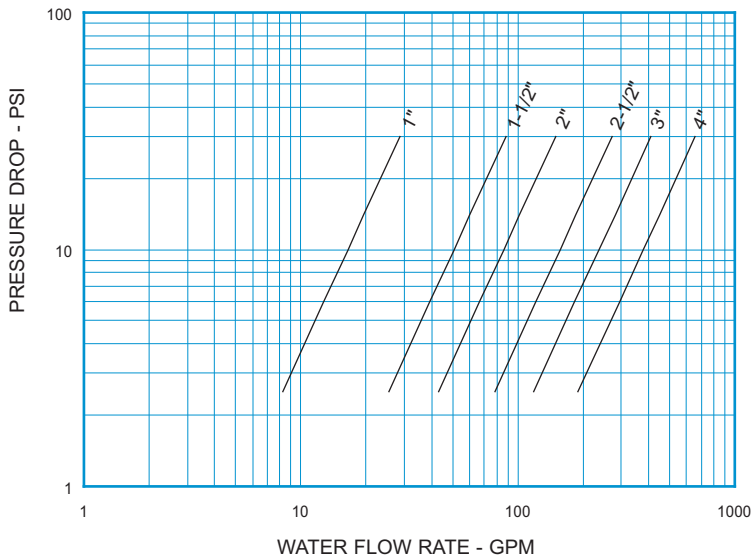

STYLE 3S C <sub>v</sub> VALUES & VALVE WEIGHTS		
C <sub>v</sub>	SIZE	316/316L SS
5.2	1	2.3 oz.
16.1	1-1/2	6.2 oz.
27.2	2	13.9 oz.
49.4	2-1/2	1.5 lb.
74.9	3	1.9 lb.
120.0	4	3.9 lb.

See page 49 for Flow Formulae.  
Valve weights are approximate.

**Note:** All flow curves and Cv values presume the valves are fully open with 1/2 PSI cracking pressure springs. Consult the factory for more information.

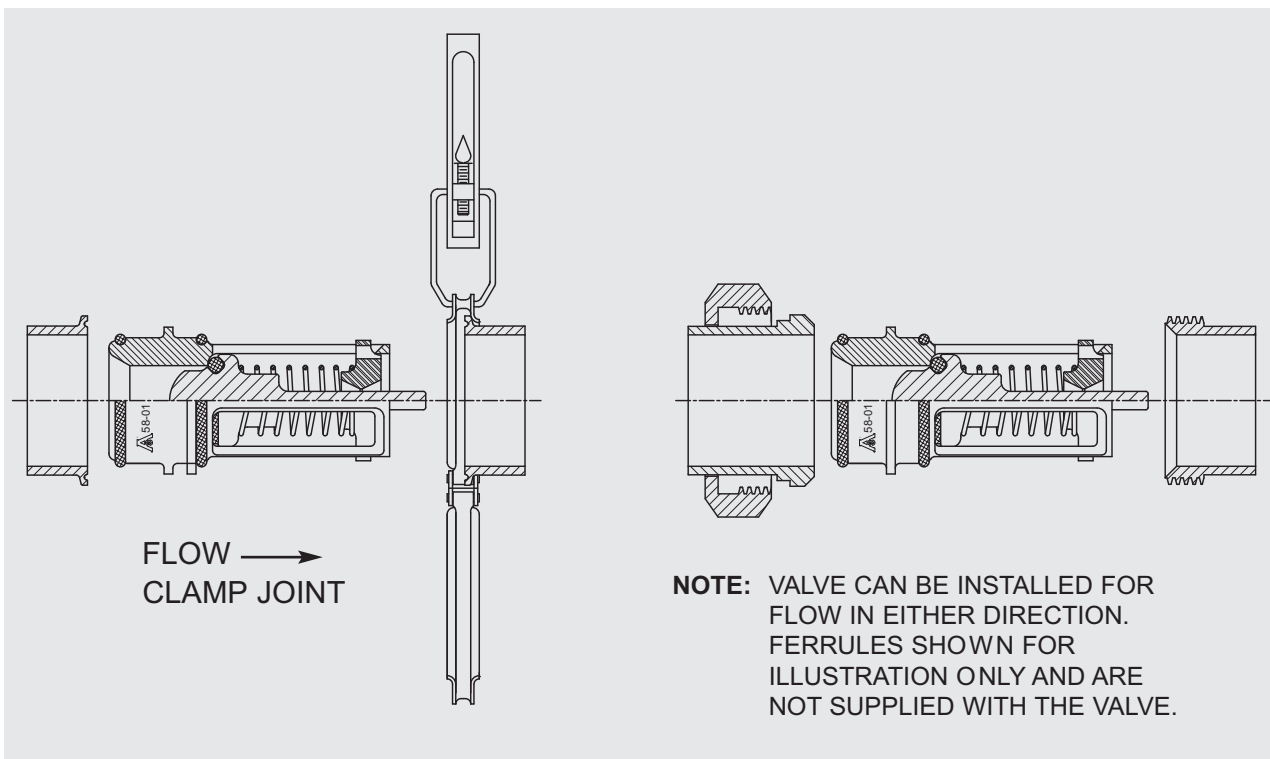

## HOW TO ORDER CHECK-ALL STYLE 3S

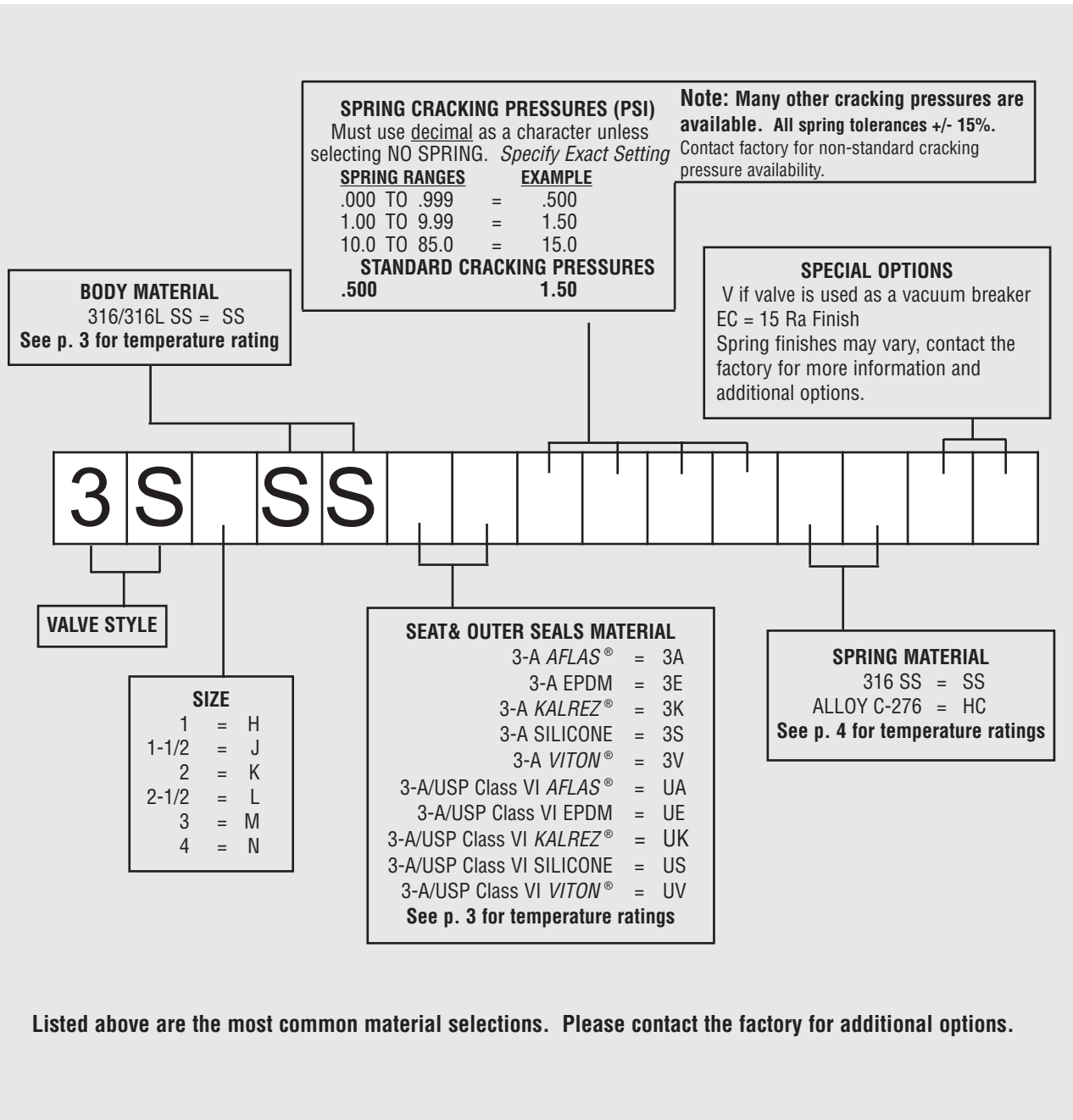

Listed above are the most common material selections. Please contact the factory for additional options.





See page 56  
Non-PED statement

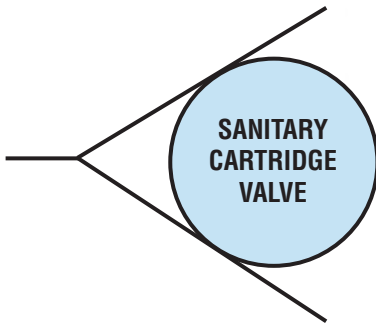

Valve shown in ferrules.  
Ferrules and clamp not included.

The **Sanitary Cartridge (SC)** valve is a stainless steel check valve for use with new or existing sanitary ferrules. The SC design seals on the ID of ferrules with replaceable food grade seals (Standard is FDA EPDM). The valve fits the Alfa Laval Inc. Bevel Seat and Tri-Clamp® fittings, Waukesha Cherry-Burrell® Q-Line and S-Line fittings and others with ID dimensions equal to the “F” dimensions listed below (ferrules not included). The compact SC design fits inside a single fitting and requires no additional space in the line. Its size makes it extremely economical when compared to full-bodied valves.

**For applications requiring a 3-A compliant valve, see our 3S series on page 23.**

The SC valve can also be used as a low pressure relief valve or vacuum breaker by using the desired spring settings.

**Note: USP Class VI o-rings can be supplied with certification.**

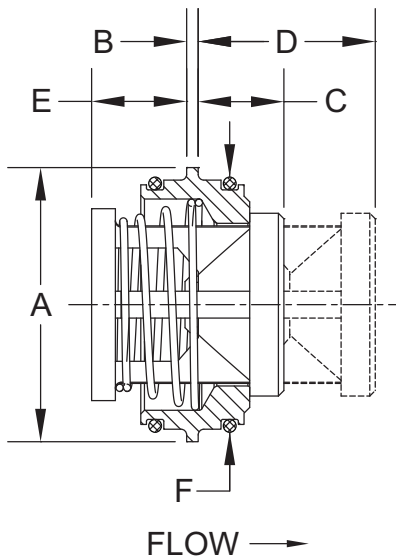

Line Size	Size Code	A	B	C ①	D ②	E	F ③	Orifice Diameter
3/4	F	3/4	1/16	0.44	0.78	0.28	0.620	0.348
1	H	1	1/16	0.53	0.89	0.30	0.870	0.464
1-1/2	J	1-1/2	1/16	0.53	1.06	0.63	1.370	0.890
2	K	2	1/16	0.66	1.39	0.66	1.870	1.135
2-1/2	L	2-1/2	1/16	0.69	1.56	0.88	2.370	1.385
3	M	3	1/16	0.75	1.97	1.25	2.870	2.025
4	N	4	1/16	0.88	2.41	1.63	3.834	2.560

- ① Maximum nominal dimension for valve closed.
- ② Maximum nominal dimension for a fully open valve with no spring.
- ③ Valves are designed to function with fittings having these internal diameters. (±0.005)

Body Material ④	Line Size	Non-Shock Pressure-Temperature Rating ⑤
316/316L Stainless Steel (SS)	3/4" - 1-1/2"	1000 PSIG @ 100°F
	2" - 4"	725 PSIG @ 100°F

- ④ See page 54 for material grade information.
- ⑤ Consult the factory for applications where higher pressure or temperature is required.





See page 56  
Non-PED statement

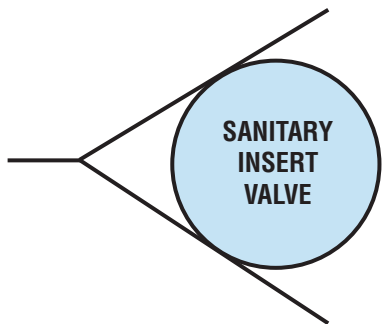

Valve shown in ferrules. Ferrules and clamp not included.

The **Sanitary Insert (CB, TC)** valve is a compact fluoropolymer (PTFE/FEP/PFA) valve which has been used for over 45 years as the most economical solution for providing a check valve in a new or existing sanitary piping system. This valve style is designed to fit into grooved-end clamp-type fittings (ferrules not included). Since the Sanitary Insert Valve replaces the gasket normally used with clamp joints, no extra space is required to accommodate the valve. The Sanitary Insert valve can also be used as a low pressure relief valve or vacuum breaker by using the desired spring settings. **For applications requiring a 3-A compliant valve, see our 3S series on page 23.**

Two different types of Sanitary Insert Valves are available. They are distinguished by the following designations in their part numbers:

**TC** – Designates Tri-Clamp® fittings manufactured by Alfa Laval Inc., as well as Waukesha Cherry-Burrell® S-Line Series of fittings.

**CB** – Designates the Waukesha Cherry-Burrell® Q-Line Series of fittings.

**NOTE:** Sanitary Insert Valve types TC and CB are not interchangeable!

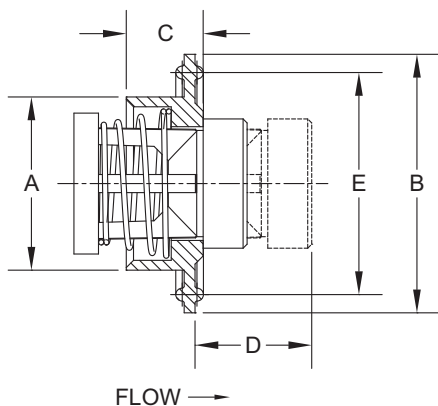

Line Size	Size Code	TC - Alfa Laval Inc. Waukesha Cherry-Burrell® S-Line					CB - Waukesha Cherry-Burrell® Q-Line Only					Orifice ① Dia.
		A	B	C	D ②	E	A	B	C	D ②	E	
3/4	F	0.590	55/64	0.55	0.63	0.800	-	-	-	-	-	0.348
1	H	0.855	2	0.55	0.70	1.718	0.850	1-3/4	0.55	0.70	1.437	0.464
1-1/2	J	1.345	2	0.60	0.98	1.718	1.350	2	0.60	0.98	1.716	0.890
2	K	1.845	2-1/2	0.57	1.12	2.218	1.850	2-1/2	0.57	1.12	2.247	1.135
2-1/2	L	2.355	3	0.60	0.98	2.781	2.250	3-1/4	0.60	0.98	2.841	1.385
3	M	2.845	3-1/2	0.64	1.59	3.281	2.852	3-55/64	0.61	1.58	3.372	2.025
4	N	3.806	4-5/8	0.78	1.90	4.344	3.800	4-55/64	0.73	1.89	4.372	2.560

① Due to molding process, orifice may vary.

② Maximum nominal dimension for a fully open valve with no spring.

Body Material ③	Line Size	Non-Shock Pressure-Temperature Rating ④
PTFE (TF)	3/4" - 2"	55 PSIG @ 100°F
	2-1/2" - 4"	20 PSIG @ 100°F

③ See page 54 for material grade information.

④ Consult the factory for reduced P-T rating of PTFE valves above 100°F.

**Note:** All flow curves and Cv values presume the valves are fully open with 1/2 PSI cracking pressure springs. Consult the factory for more information.

**Sanitary Insert Valve**  
For Water at 72°F

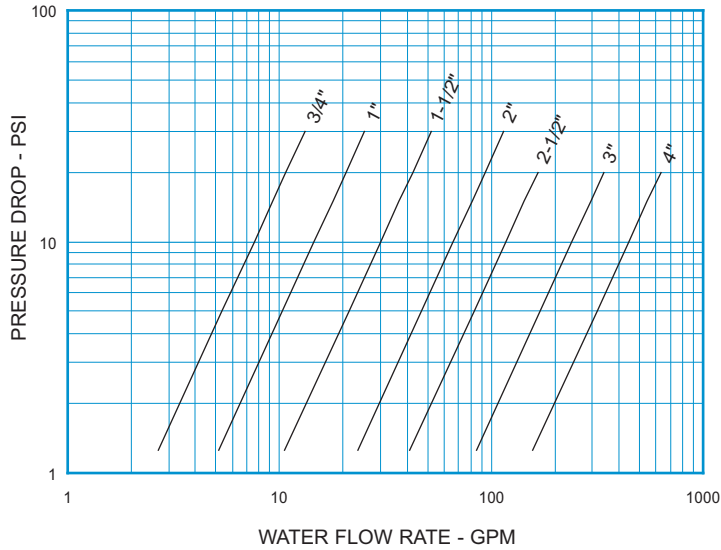

STYLE CB, TC C <sub>v</sub> VALUES & VALVE WEIGHTS		
C <sub>v</sub>	SIZE	PTFE
2.4	3/4	0.2 oz.
4.6	1	0.6 oz.
9.5	1-1/2	1.1 oz.
20.9	2	1.8 oz.
37.0	2-1/2	2.3 oz.
76.0	3	5.1 oz.
141	4	11.2 oz.

See page 49 for Flow Formulae.  
Valve weights are approximate.

**HOW TO ORDER  
CHECK-ALL STYLE CB, TC**

**BODY MATERIAL**  
PTFE = TF  
See p. 3 for temperature rating

**SPRING CRACKING PRESSURES (PSI)**  
Must use decimal as a character unless selecting NO SPRING. *Specify Exact Setting*

SPRING RANGES	EXAMPLE
.000 TO .999	= .500
1.00 TO 9.99	= 1.50
10.0 TO 85.0	= 15.0
NO SPRING	= NOSPRG

**STANDARD CRACKING PRESSURES ①**  
.125 .500 1.50 3.50  
(Sizes F-K Only)

**Note:** Many other cracking pressures are available. All spring tolerances +/- 15%.

**VALVE STYLE**  
SIV-CB = CB  
SIV-TC = TC

**SIZE**

3/4	= F
1	= H
1-1/2	= J
2	= K
2-1/2	= L
3	= M
4	= N

**SEAT MATERIAL**

AFLAS® = AS	"METAL-TO-METAL" ② = MT
BUNA-N = BN	NEOPRENE = NE
FDA AFLAS® = FA	FDA BUNA = FB
EPDM/FDA EPDM = FE	FDA VITON® = FV
KALREZ® = KZ	VITON® = VT

See p. 3 for temperature ratings

**SPRING MATERIAL**

316 SS	= SS
ALLOY C-276	= HC
ALLOY X750 OR INCONEL® X750	= IX
ALLOY 400 OR MONEL®	= MO
TITANIUM	= TI

See p. 4 for temperature ratings

**SPECIAL OPTIONS**  
T = FEP ENCAPSULATED SPRING  
See p. 4 for temperature rating  
Contact the factory for more options

Listed above are the most common material selections. Please contact the factory for additional options.

① .500 PSI is the only standard cracking pressure for spring materials other than Stainless Steel. .125 PSI springs are not recommended for installations with flow vertical down.

② For PTFE valves, "MT" seats mean plastic to plastic. (No o-ring). See page 50 for allowable leakage rates.

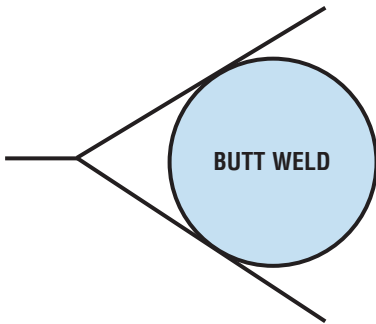

The **Butt Weld (B4, B8)** check valve is a one piece body machined from bar stock, eliminating porosity concerns and providing uniform density for more consistent welds. Made to ASME/ANSI B16.25 for schedule 40 pipe (B4), or schedule 80 pipe (B8) it carries rugged, dependable Check-All® trim with a wide variety of seat materials and cracking pressures to choose from. The Butt Weld valve can also be used as a low pressure relief valve or vacuum breaker by using the desired spring settings.

**CAUTION:** Please take sufficient measures when welding to prevent heat build-up and possible damage to the valve seat. See page 51 for additional installation information.

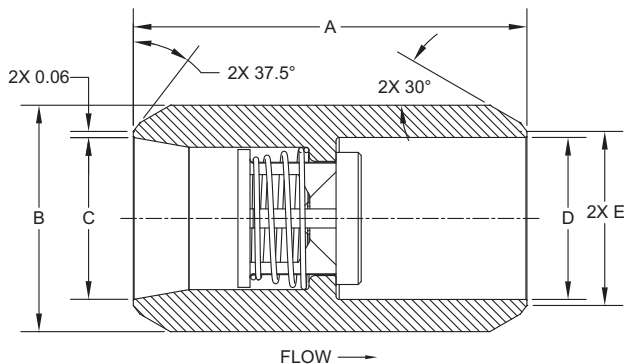

**NOTE:** Many valves in this series can be supplied with B16.34 certification. Consult the factory for more information.

Nom. Pipe Size	Size Code	A	B ①	B4 Valve C & D	B8 Valve C & D	E	Orifice Diameter
1/2	D	2.16	15/16	0.622	0.546	0.84	0.348
3/4	F	2.71	1-3/16	0.824	0.742	1.05	0.464
1	H	2.95	1-1/2	1.049	0.957	1.32	0.593
1-1/4	I	3.64	1-7/8	1.380	1.278	1.66	0.890
1-1/2	J	3.91	2-1/4	1.610	1.500	1.90	1.135
2	K	4.36	2-3/4	2.067	1.939	2.38	1.385
2-1/2	L	5.00	3-1/4	2.469	2.323	2.88	1.555
3	M	5.44	3-3/4	3.068	2.900	3.50	2.025
4	N	6.80	4-3/4	4.026	3.826	4.50	2.560

① May be larger.

Body Material ②	Availability	Non-Shock Pressure-Temperature Rating			
316/316L Stainless Steel (SS)	Standard	1/2" - 1"	1-1/4" - 2-1/2"	3"	4"
Carbon Steel (CS)					
Alloy 20 (A2)	Semi-standard	5000 PSIG @ 100°F (1500 PSIG for o-ring seats)	4000 PSIG @ 100°F (1500 PSIG for o-ring seats)	3000 PSIG @ 100°F (1500 PSIG for o-ring seats)	1500 PSIG @ 100°F
Alloy C-276 (HC)					
Alloy 400 or Monel® (MO)					
Alloy B (HB)	Contact the factory for these or other materials				

② See page 53 for material grade information.

**Butt Weld Valve**  
For Water at 72°F

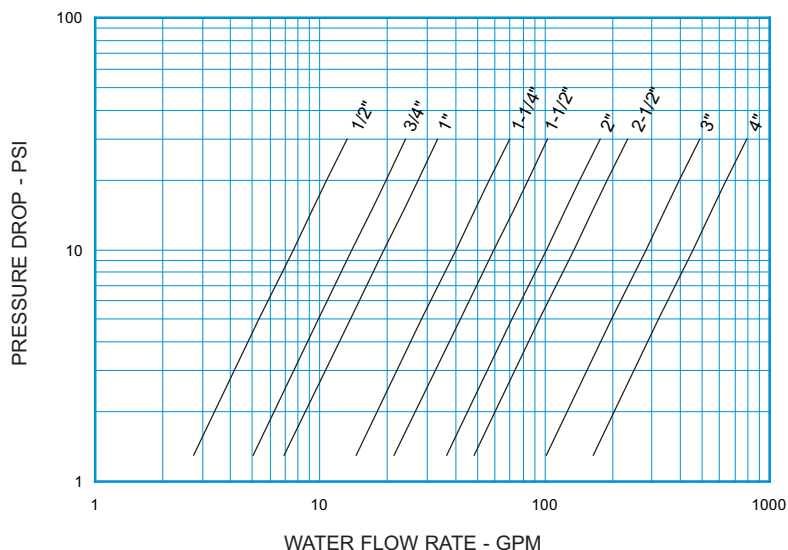

STYLE B4 C <sub>v</sub> VALUES & VALVE WEIGHTS		
C <sub>v</sub>	SIZE	SS & CS Alloys
2.4	1/2	4.6 oz.
4.4	3/4	9.1 oz.
6.1	1	15.0 oz.
12.7	1-1/4	1.7 lb.
18.8	1-1/2	2.6 lb.
32.0	2	4.1 lb.
42.5	2-1/2	6.3 lb.
89.0	3	8.4 lb.
144	4	15.2 lb.

See page 49 for Flow Formulae.  
Valve weights are approximate.

**HOW TO ORDER  
CHECK-ALL STYLE B4, B8**

**BODY MATERIAL**  
ALLOY 20 = A2  
CARBON STEEL = CS  
ALLOY B = HB  
ALLOY C-276 = HC  
ALLOY 400 OR MONEL® = MO  
316/316L SS = SS  
See p. 3 for temperature ratings

**SPRING CRACKING PRESSURES (PSI)**  
Must use decimal as a character unless selecting NO SPRING. *Specify Exact Setting*  
**SPRING RANGES**      **EXAMPLE**  
.000 TO .999      =      .500  
1.00 TO 9.99      =      1.50  
10.0 TO 85.0      =      15.0  
NO SPRING      =      NOSPRG  
**STANDARD CRACKING PRESSURES ①**  
.125    .500    1.50    3.50  
(Sizes D-J Only)

**Note:** Many other cracking pressures are available. All spring tolerances +/- 15%.

**SPECIAL OPTIONS**  
T = FEP ENCAPSULATED SPRING  
See p. 4 for temperature rating  
Contact the factory for more options



**VALVE STYLE**  
SCH 40 PIPE = B4  
SCH 80 PIPE = B8

**SIZE**  
1/2 = D  
3/4 = F  
1 = H  
1-1/4 = I  
1-1/2 = J  
2 = K  
2-1/2 = L  
3 = M  
4 = N

**SEAT MATERIAL ②**  
AFLAS® = AS  
BUNA-N = BN  
EPDM ③ = EP  
KALREZ® = KZ  
“METAL-TO-METAL” = MT  
NEOPRENE = NE  
PTFE = TF  
VITON® = VT  
See p. 3 for temperature ratings

**SPRING MATERIAL**  
316 SS = SS  
ALLOY C-276 = HC  
ALLOY B = HB  
ALLOY X750 OR INCONEL® X750 = IX  
ALLOY 400 OR MONEL® = MO  
17-7PH SS = PH  
TITANIUM = TI  
See p. 4 for temperature ratings

Listed above are the most common material selections. Please contact the factory for additional options.

- ① .500 PSI is the only standard cracking pressure for spring materials other than Stainless Steel. .125 PSI springs are not recommended for installations with flow vertical down.
- ② Seat materials other than “metal-to-metal” have a maximum pressure rating of 1500 PSI. “Metal-to-Metal” and PTFE seats are not resilient. See page 50 for allowable leakage rates.
- ③ EP seats not recommended for use with Carbon Steel valves.



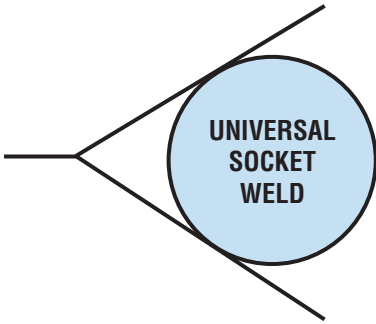
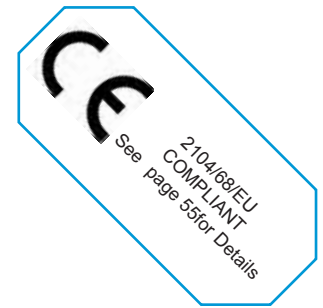

The **Universal Socket Weld (US)** check valve is a one piece body machined from bar stock with socket weld ends and is designed for a minimum pressure drop. It carries rugged, dependable Check-All® trim and there are a wide variety of seat materials and cracking pressures to choose from. The socket ends are machined to ASME/ANSI B16.11 dimensions. The US valve can also be used as a low pressure relief valve or vacuum breaker by using the desired spring settings.

**CAUTION:** Please take sufficient measures when welding to prevent heat build-up and possible damage to the valve seat. See page 51 for additional installation information.

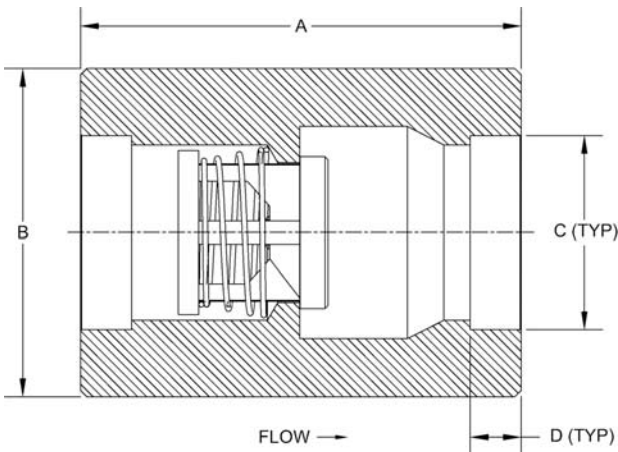

Nom. Pipe Size	Size Code	A	B ①	C ②	D ②	Orifice Diameter
3/8	C	2.16	1-1/8	0.695	0.385	0.348
1/4	B	2.16	1	0.563	0.385	0.348
1/2	D	2.71	1-5/16	0.860	0.385	0.464
3/4	F	2.95	1-5/8	1.070	0.505	0.593
1	H	3.64	2-1/4	1.335	0.505	0.890
1-1/4	I	3.91	2-3/4	1.680	0.505	1.135
1-1/2	J	4.36	3-1/4	1.920	0.505	1.385
2	K	5.85	3-1/2	2.411	0.625	1.555
2-1/2	L	5.00	3-3/4	2.919	0.625	1.555
3	M	5.44	4-1/2	3.545	0.625	2.025
4	N	6.80	5-1/2	4.550	0.755	2.560

① May be larger.  
 ② Sockets per ASME/ANSI B16.11.

**NOTE:** Many valves in this series can be supplied with B16.34 certification. Consult the factory for more information.

Body Material ③	Availability	Non-Shock Pressure-Temperature Rating		
316/316L Stainless Steel (SS)	Standard	3/8" - 2-1/2"	3"	4"
Carbon Steel (CS)				
Alloy 20 (A2)	Semi-standard	5000 PSIG @ 100°F (1500 PSIG for o-ring seats)	3000 PSIG @ 100°F (1500 PSIG for o-ring seats)	1500 PSIG @ 100°F
Alloy C-276 (HC)				
Alloy 400 or Monel® (MO)				
Alloy B (HB)	Contact the factory for these or other materials			

③ See page 54 for material grade information.

Note: All flow curves and Cv values presume the valves are fully open with 1/2 PSI cracking pressure springs. Consult the factory for more information.

**Universal Socket Weld**  
For Water at 72°F

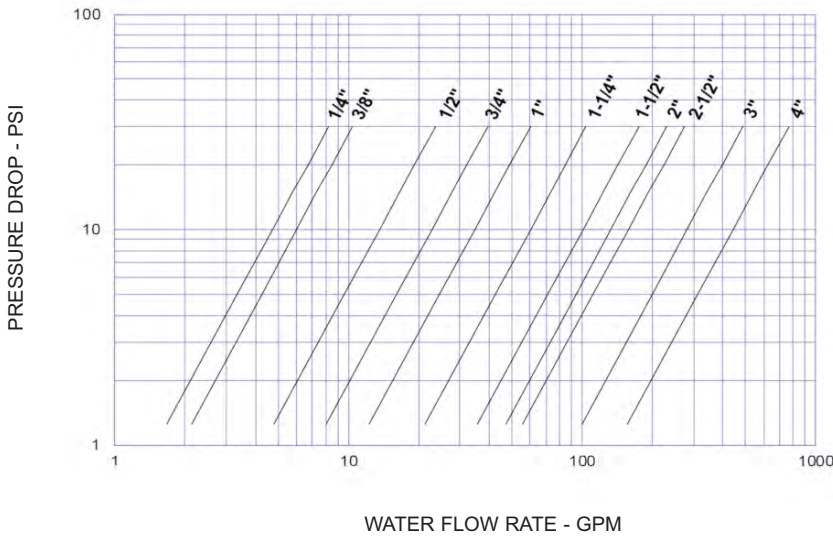

STYLE US C <sub>v</sub> VALUES & VALVE WEIGHTS		
C <sub>v</sub>	SIZE	SS & CS ALLOYS
1.5	1/4	4.0 oz.
1.9	3/8	5.1 oz.
4.3	1/2	11.5
7.2	3/4	1.2 lb.
11.0	1	3.1 lb.
19.0	1-1/4	4.9 lb.
31.9	1-1/2	7.4 lb.
42.0	2	9.8 lb.
50.0	2-1/2	8.8 lb.
89.0	3	13 lb.
140	4	22.3 lb.

See page 49 for Flow Formulae.  
Valve weights are approximate.

**HOW TO ORDER  
CHECK-ALL STYLE US**

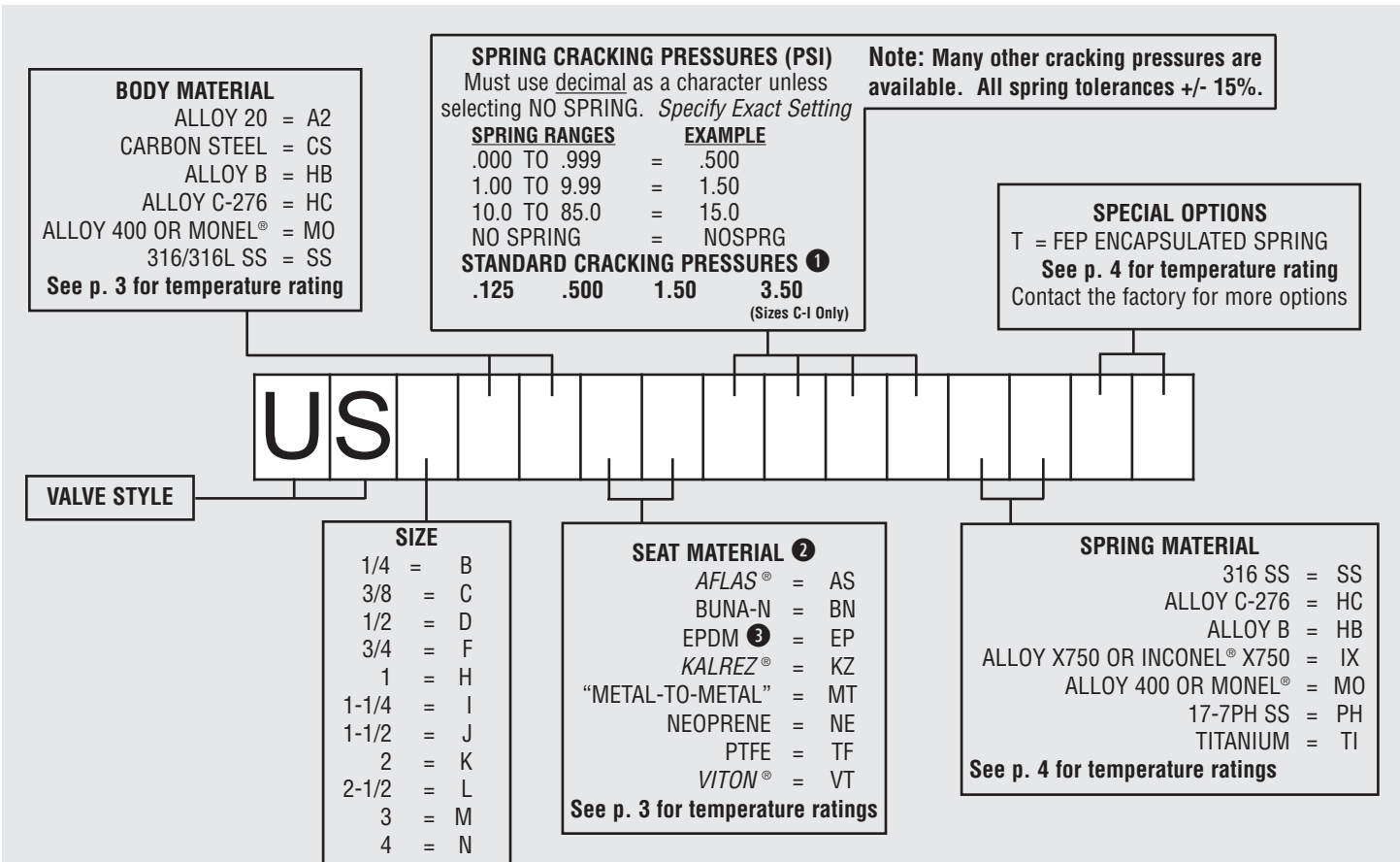

Listed above are the most common material selections. Please contact the factory for additional options.

- ① .500 PSI is the only standard cracking pressure for spring materials other than Stainless Steel. .125 PSI springs are not recommended for installations with flow vertical down.
- ② Seat materials other than "metal-to-metal" have a maximum pressure rating of 1500 PSI. "Metal-to-Metal" and PTFE seats are not resilient. See page 50 for allowable leakage rates.
- ③ EP seats not recommended for use with Carbon Steel valves.

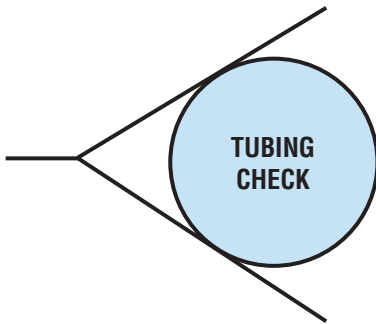

The **Tubing Check (TV)** valve is constructed with compression tube fittings (flareless) and is designed for a minimum pressure drop. The valves are furnished complete with ferrules and nuts. The TV valve can also be used as a low pressure relief valve or vacuum breaker by using the desired spring settings.

**NOTE:** Consult the factory for instrumentation applications or for more information.

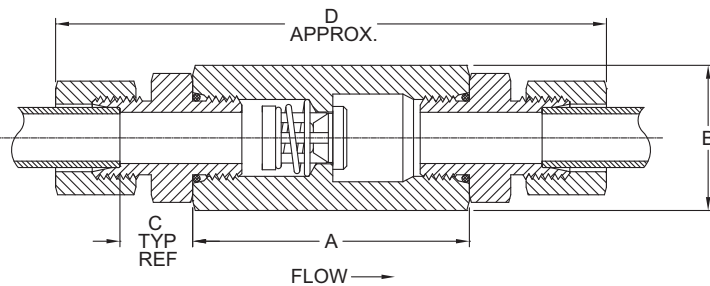

**NOTE:** Many valves in this series can be supplied with B16.34 certification. Consult the factory for more information.

Tubing O.D. Size	Size Code	A	Hex <sup>1</sup> Size B	C	D	Orifice Diameter
1/8	A	2.16	7/8	0.42	3.99	0.348
1/4	B	2.16	7/8	0.57	4.58	0.348
3/8	C	2.16	7/8	0.57	4.80	0.348
1/2	D	2.48	1-1/8	0.63	5.44	0.464
5/8	E	2.63	1-1/4	0.72	5.89	0.464
3/4	F	2.93	1-1/2	0.85	6.47	0.593
7/8	G	3.34	1-7/8	0.85	6.98	0.890
1	H	3.34	1-7/8	0.81	7.18	0.890
1-1/4	I	3.48	2-1/4	0.89	7.56	1.135
1-1/2	J	3.81	2-1/2	0.89	7.99	1.385
2	K	5.09	3-1/2	1.05	9.66	2.025

<sup>1</sup>May be larger and/or round.

Line Size	Non-Shock Pressure-Temperature Rating <sup>2</sup>	
	Stainless Steel (SS) and Carbon Steel <sup>3</sup>	Brass (BR) <sup>3</sup>
1/8"	4500 PSIG @ 100°F	3000 PSIG @ 100°F
1/4" - 1/2"	5000 PSIG @ 100°F	3000 PSIG @ 100°F
5/8"	5000 PSIG @ 100°F	1600 PSIG @ 100°F
3/4"	4500 PSIG @ 100°F	1600 PSIG @ 100°F
7/8" - 1"	4000 PSIG @ 100°F	1600 PSIG @ 100°F
1-1/4" - 1-1/2"	3000 PSIG @ 100°F	1600 PSIG @ 100°F
2"	2000 PSIG @ 100°F	1600 PSIG @ 100°F

<sup>2</sup>Maximum Pressure 1500 PSIG for o-ring seats.

<sup>3</sup>See page 54 for material grade information.

**Note:** All flow curves and Cv values presume the valves are fully open with 1/2 PSI cracking pressure springs. Consult the factory for more information.

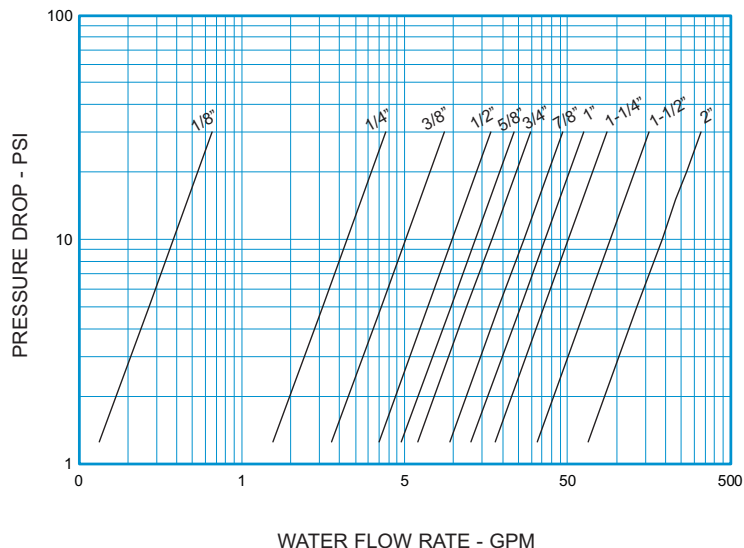

STYLE TV C <sub>v</sub> VALUES & VALVE WEIGHTS		
C <sub>v</sub>	SIZE	ALL MATL
0.06	1/8	6.9 oz.
0.6	1/4	7.6 oz.
1.4	3/8	8.1 oz.
3.1	1/2	13 oz.
4.3	5/8	1.8 lb.
5.4	3/4	2.3 lb.
8.5	7/8	2.7 lb.
11.5	1	3.0 lb.
16.0	1-1/4	4.9 lb.
29.0	1-1/2	7.8 lb.
60.0	2	15 lb.

See page 49 for Flow Formulae.  
Valve weights are approximate.

## HOW TO ORDER CHECK-ALL STYLE TV

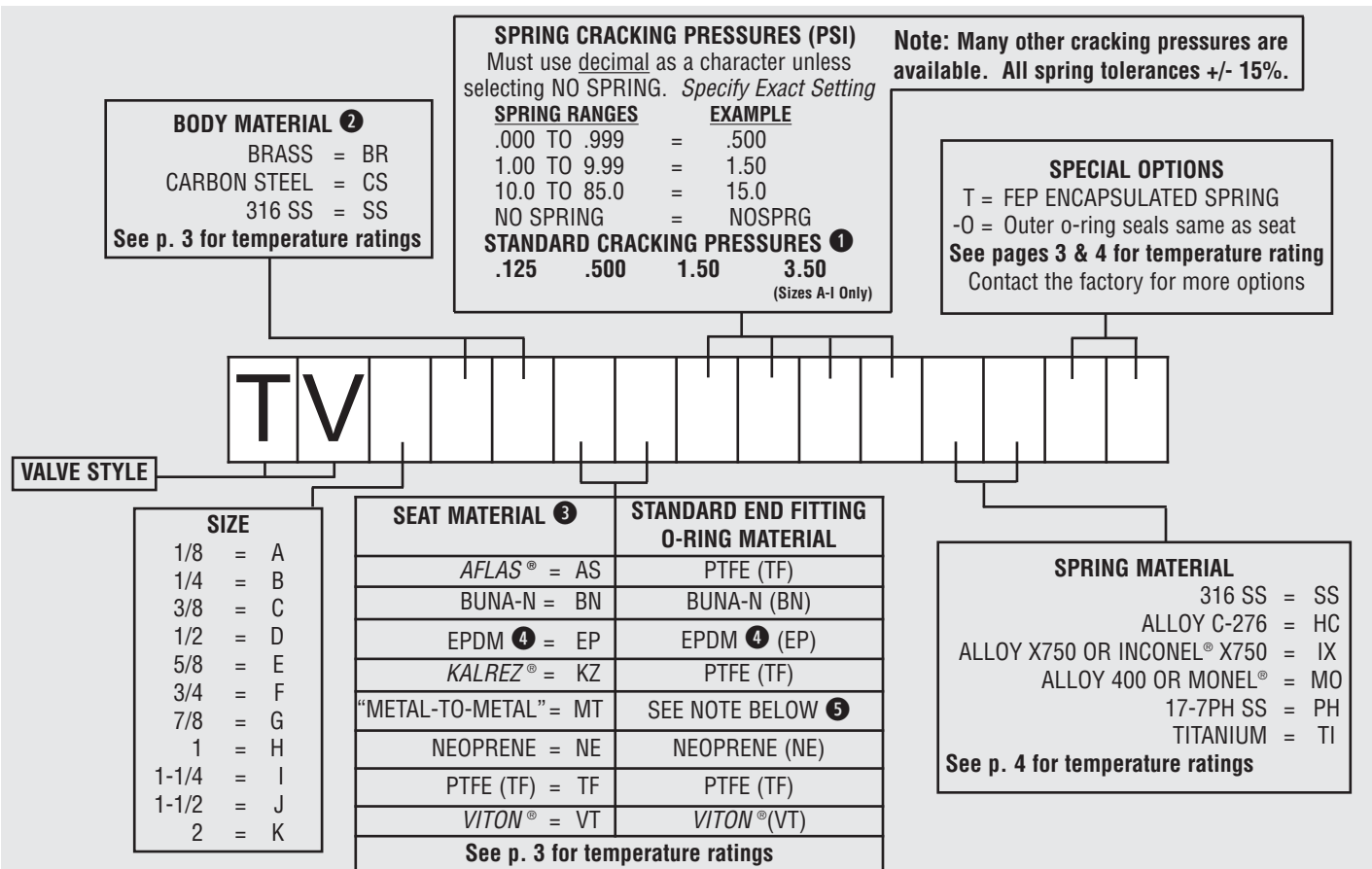

Listed above are the most common material selections. Please contact the factory for additional options.

- ① .500 PSI is the only standard cracking pressure for spring materials other than Stainless Steel. .125 PSI springs are not recommended for installations with flow vertical down.
- ② Brass valves have plated Carbon Steel tube fittings if applicable. Consult factory if other body or fitting materials are desired.
- ③ Seat materials other than “metal-to-metal” have a maximum pressure rating of 1500 PSI. “Metal-to-Metal” and PTFE seats are not resilient. See page 50 for allowable leakage rates.
- ④ EP seats not recommended for use with Carbon Steel valves.
- ⑤ Fitting o-rings are the same as the seat for standard seat materials. For “metal-to-metal” seated valves, end fitting o-rings are Buna-N for brass and carbon steel valves and Viton® for stainless steel valves. Consult the factory for further information.

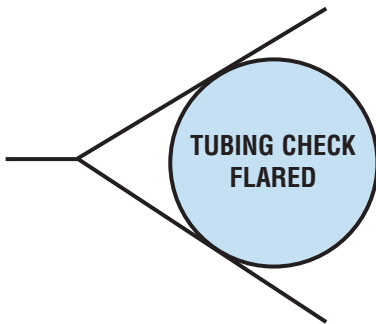

The **Tubing Check Valve-Flared (TF)** is a three-piece constructed check valve with 37° flared end fittings that conform to SAE J514 & ISO 8434-2 . These valves are designed for maximum flow with minimal pressure drop. The TF valve can also be used as a low pressure relief valve or vacuum breaker by using the desired spring settings.

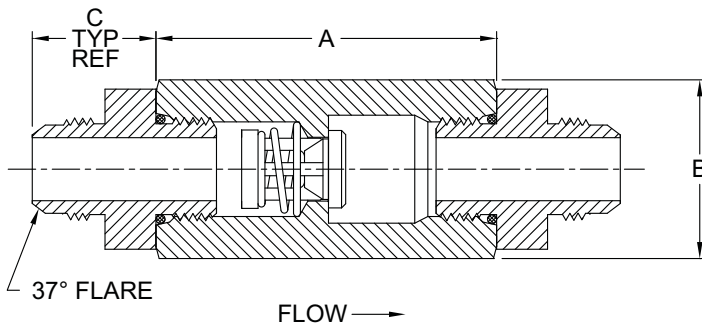

Tubing O.D. Size	Size Code	A	Hex <sup>①</sup> Size B	C	Orifice Diameter
1/8	A	2.16	7/8	0.69	0.348
1/4	B	2.16	7/8	0.89	0.348
3/8	C	2.16	7/8	0.91	0.348
1/2	D	2.47	1-1/8	1.04	0.464
5/8	E	2.63	1-1/4	1.20	0.464
3/4	F	2.92	1-1/2	1.38	0.593
7/8	G	3.34	1-7/8	1.40	0.890
1	H	3.34	1-7/8	1.46	0.890
1-1/4	I	3.48	2-1/4	1.58	1.135
1-1/2	J	3.81	2-1/2	1.79	1.385
2	K	5.09	3-1/2	2.19	2.025

<sup>①</sup>May be larger and/or round.

Line Size	Non-Shock Pressure-Temperature Rating <sup>②</sup>		
	Stainless Steel (SS) <sup>③</sup>	Carbon Steel (CS) <sup>③</sup>	Brass (BR) <sup>③</sup>
1/8" - 1/2"	7700 PSIG @ 100°F	6000 PSIG @ 100°F	3000 PSIG @ 100°F
5/8" - 3/4"	6000 PSIG @ 100°F	5000 PSIG @ 100°F	1600 PSIG @ 100°F
7/8"	5400 PSIG @ 100°F	5000 PSIG @ 100°F	1600 PSIG @ 100°F
1"	5400 PSIG @ 100°F	4500 PSIG @ 100°F	1600 PSIG @ 100°F
1-1/4"	3600 PSIG @ 100°F	4000 PSIG @ 100°F	1600 PSIG @ 100°F
1-1/2"	2400 PSIG @ 100°F	3000 PSIG @ 100°F	1600 PSIG @ 100°F
2"	1800 PSIG @ 100°F	2000 PSIG @ 100°F	1600 PSIG @ 100°F

<sup>②</sup>Maximum Pressure 1500 PSIG for o-ring seats.

<sup>③</sup>See page 54 for material grade information.



Note: All flow curves and Cv values presume the valves are fully open with 1/2 PSI cracking pressure springs. Consult the factory for more information.

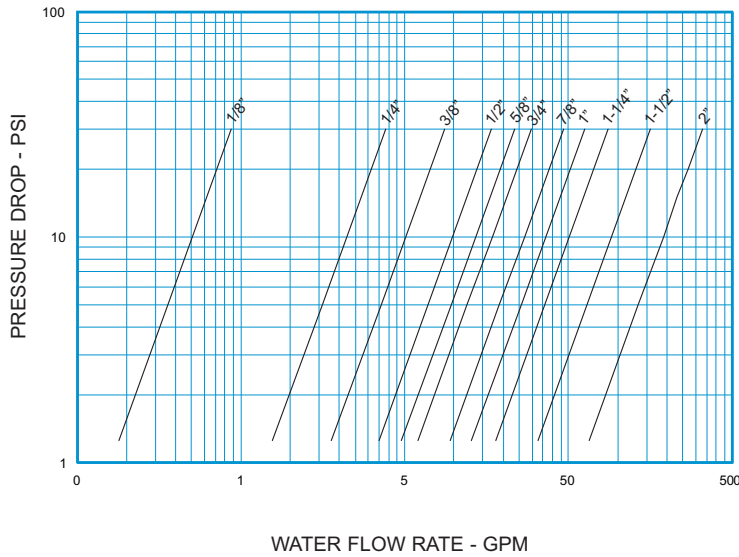

STYLE TF C <sub>v</sub> VALUES & VALVE WEIGHTS		
C <sub>v</sub>	SIZE	ALL MATL
0.08	1/8	5.5 oz.
0.7	1/4	6.6 oz.
1.6	3/8	7.2 oz.
3.1	1/2	13 oz.
4.3	5/8	1.8 lb.
5.4	3/4	2.3 lb.
8.5	7/8	2.7 lb.
11.5	1	3.0 lb.
16.0	1-1/4	5.7 lb.
29.0	1-1/2	7.8 lb.
60.0	2	15 lb.

See page 49 for Flow Formulae.  
Valve weights are approximate.

## HOW TO ORDER CHECK-ALL STYLE TF

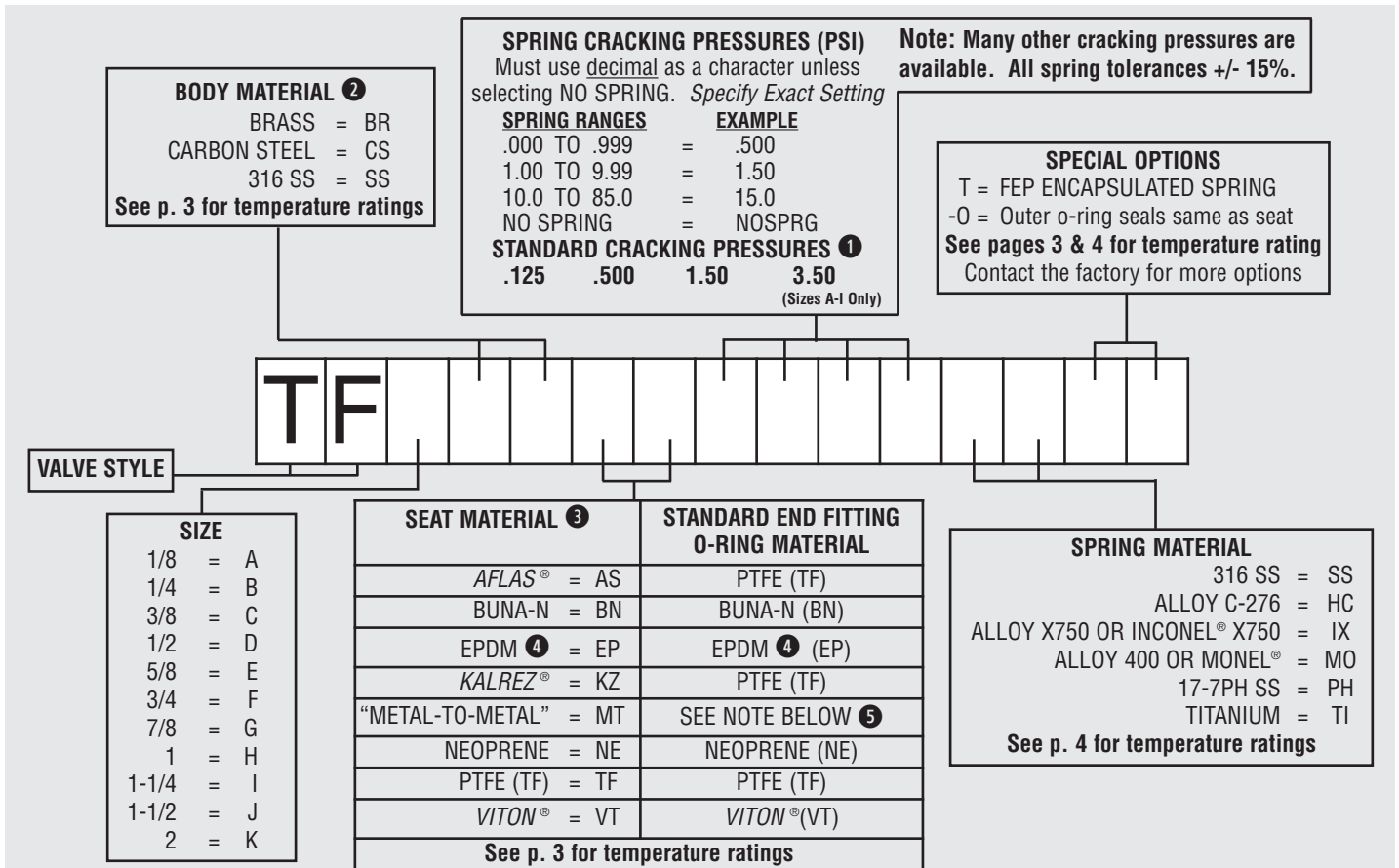

Listed above are the most common material selections. Please contact the factory for additional options.

- ① .500 PSI is the only standard cracking pressure for spring materials other than Stainless Steel. .125 PSI springs are not recommended for installations with flow vertical down.
- ② Brass valves have plated Carbon Steel tube fittings if applicable. Consult factory if other body or fitting materials are desired.
- ③ Seat materials other than “metal-to-metal” have a maximum pressure rating of 1500 PSI. “Metal-to-Metal” and PTFE seats are not resilient. See page 50 for allowable leakage rates.
- ④ EP seats not recommended for use with Carbon Steel valves.
- ⑤ Fitting o-rings are the same as the seat for standard seat materials. For “metal-to-metal” seated valves, end fitting o-rings are Buna-N for brass and carbon steel valves and Viton® for stainless steel valves. Consult the factory for further information.



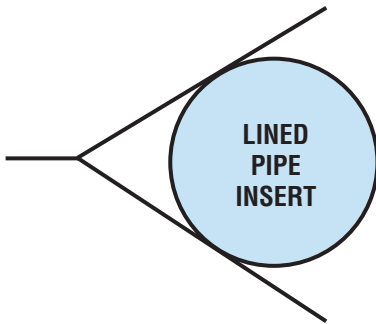

The **Lined Pipe Insert (LP)** valve is designed to mate between two flanges on most lined pipe systems. It provides the simplest and most economical way to install a check valve in a lined piping system. No gaskets are required; just spread the flanges, center the valve and bolt the flanges together. LP valves are available in fluoropolymer (PTFE/FEP/PFA) and Alloy C-276 to satisfy the most demanding applications. The standard spring material is Alloy C-276. Other materials are available upon request. The LP valve can also be used as a low pressure relief valve or vacuum breaker by using the desired spring settings.

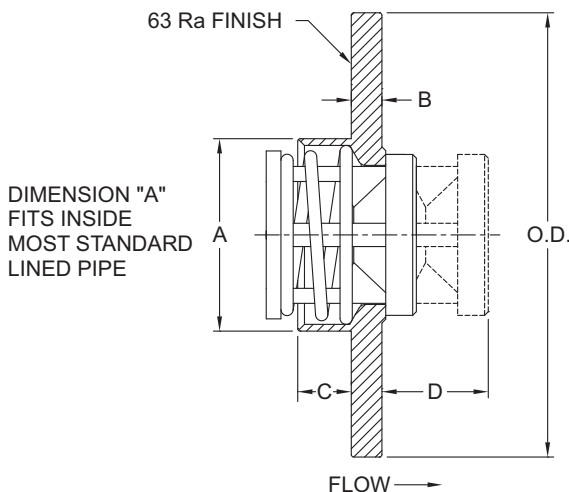

Nom. Pipe Size	Size Code	A	B	C		D <sup>1</sup>	OD	Orifice <sup>2</sup> Diameter
				PTFE	HC			
1	H	0.590	1/4	0.26	0.26	0.53	2	0.348
1-1/2	J	1.120	1/4	0.46	0.42	0.78	2-7/8	0.593
2	K	1.570	1/4	0.79	0.44	1.01	3-5/8	1.135
3	M	2.520	5/16	0.77	0.66	1.43	5	1.555 <sup>3</sup>

- <sup>1</sup> Maximum nominal dimension for a fully open valve with no spring.
- <sup>2</sup> Orifice Diameter for PTFE valve may vary due to molding process.
- <sup>3</sup> 3" PTFE valves use 1.385 Orifice Diameter.

Body Material <sup>4</sup>	Nominal Pipe Size	Non-Shock Pressure-Temperature Rating
Alloy C-276 (HC)	1" - 3"	ANSI Class 150 & 300
PTFE (TF)	1" - 2"	55 PSIG @ 100°F <sup>5</sup>
	3"	20 PSIG @ 100°F <sup>5</sup>

- <sup>4</sup> See page 54 for material grade information. Contact the factory for availability of other materials.
- <sup>5</sup> Consult the factory for reduced P-T rating above 100°F.

**Lined Pipe Insert**  
For Water at 72°F

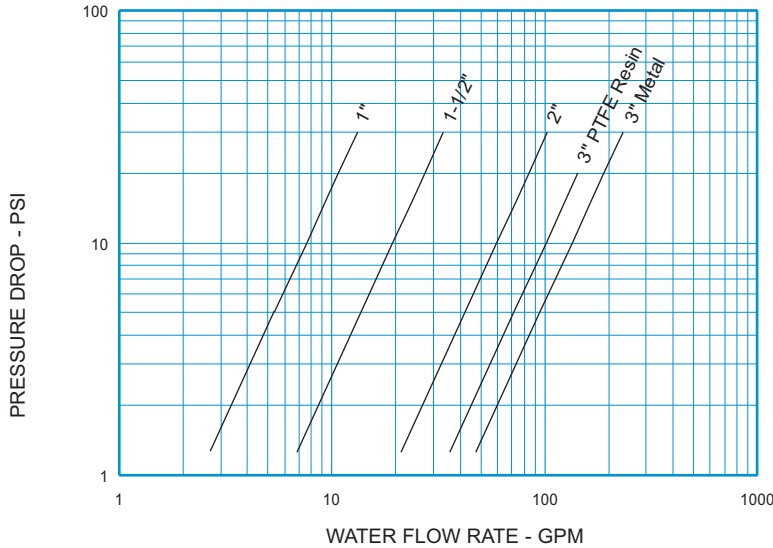

**Note:** All flow curves and Cv values presume the valves are fully open with 1/2 PSI cracking pressure springs. Consult the factory for more information.

STYLE LP C <sub>v</sub> VALUES & VALVE WEIGHTS				
METAL C <sub>v</sub>	PTFE C <sub>v</sub>	SIZE	METAL	PTFE
2.4	2.4	1	4.0 oz.	1.0 oz.
6.1	6.1	1-1/2	8.8 oz.	2.2 oz.
18.8	18.8	2	14.4 oz.	3.2 oz.
45.8	32.0	3	2.3 lb.	9.0 oz.

See page 49 for Flow Formulae.  
Valve weights are approximate.

**HOW TO ORDER  
CHECK-ALL STYLE LP**

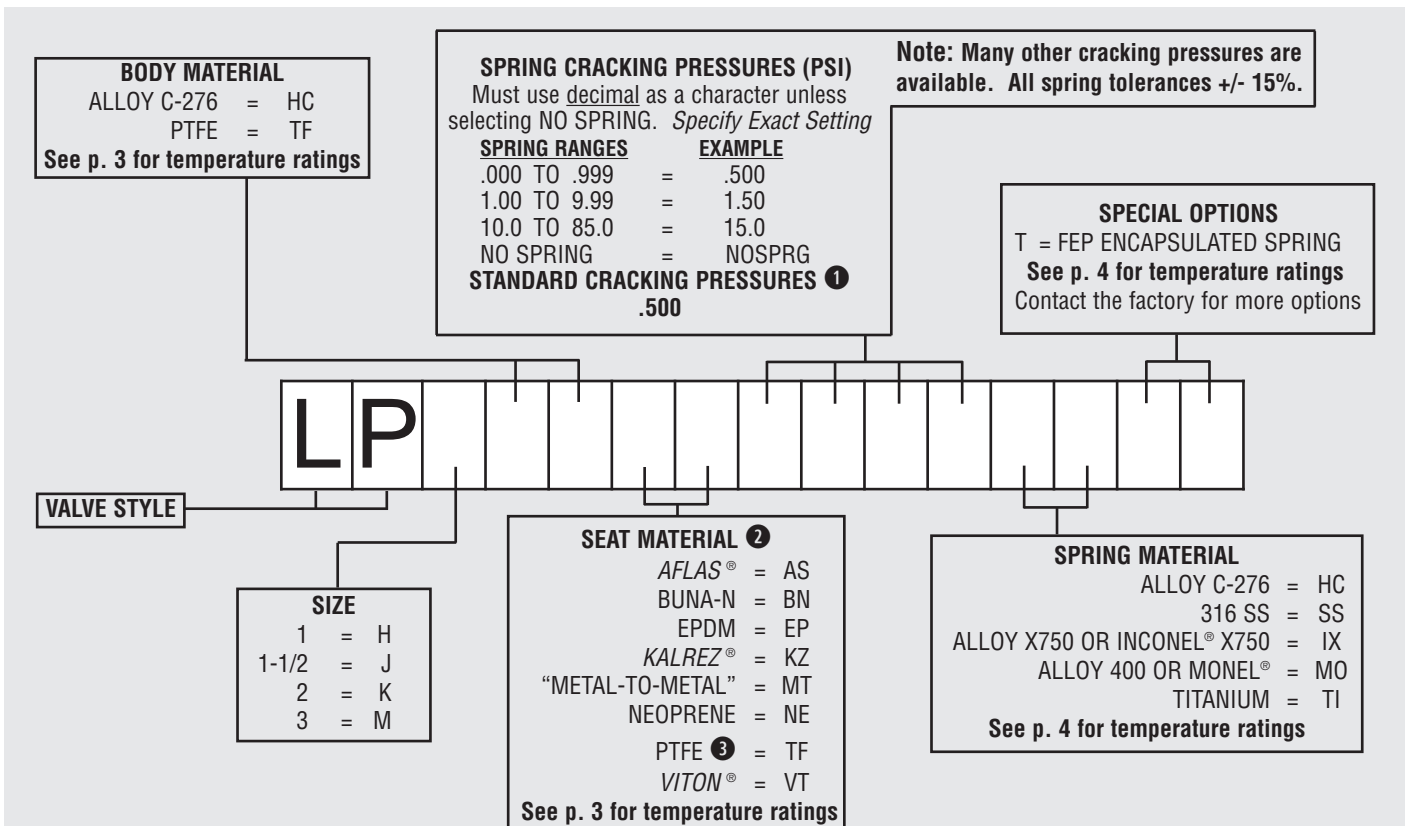

Listed above are the most common material selections. Please contact the factory for additional options.

- ① .500 PSI is the only standard cracking pressure for spring materials other than Stainless Steel. .125 PSI springs are not recommended for installations with flow vertical down.
- ② “Metal-to-Metal” and PTFE seats are not resilient. See page 50 for allowable leakage rates.
- ③ For PTFE valves, “TF” o-ring seats are not available, “MT” seats mean plastic to plastic. (No o-ring)



2104/68/EU  
COMPLIANT  
See page 55 for Details

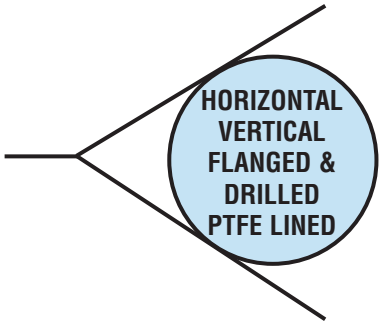

The **Check-All® Flanged & Drilled — Fluoropolymer (PTFE) Lined (HT)** check valve is a one piece body with ANSI/ASME B16.5 Class 150 flanged ends. The valve has a solid one piece PTFE liner which covers the flange faces out to the raised face diameter. All wetted surfaces are fluoropolymer (PTFE/FEP/PFA) including the FEP encapsulated stainless steel spring.

Style HT bodies are made of **cast carbon steel only**. The liner is made of virgin PTFE. It is installed as one solid piece of PTFE and the internal geometrical shape is machined. The PTFE liner has a **minimum wall** thickness of 3/32 inch, which guarantees against pin holes which can be present in fused liners.

The HT valve can also be used as a low pressure relief valve or vacuum breaker by using the desired spring settings.

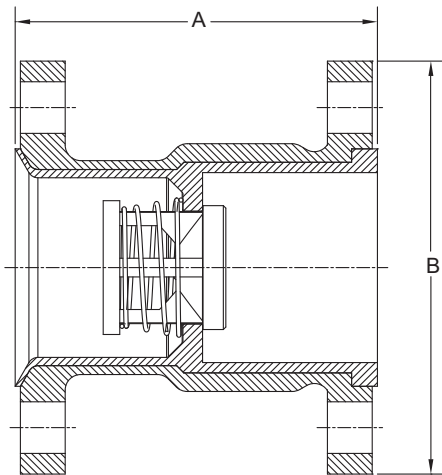

Nom. Pipe Size	Size Code	A	B	Orifice <sup>1</sup> Diameter
1	H	3.75	4-1/4	0.890
1-1/2	J	4.38	5	1.385
2	K	5.13	6	2.025

<sup>1</sup>Due to molding process, Orifice Diameter may vary.

Cast Body Material <sup>2</sup>	Liner Material <sup>2</sup>	Nominal Pipe Size	Non-Shock Pressure-Temperature Rating <sup>3</sup>
WCB/WCC Carbon Steel (CS)	PTFE (TF)	1"	55 PSIG @ 100°F
		1-1/2" - 2"	20 PSIG @ 100°F

<sup>2</sup> See page 54 for material grade information.

<sup>3</sup> Consult the factory for reduced P-T rating of PTFE valves above 100°F.

**Horizontal-Vertical Flanged & Drilled PTFE Lined**  
For Water at 72°F

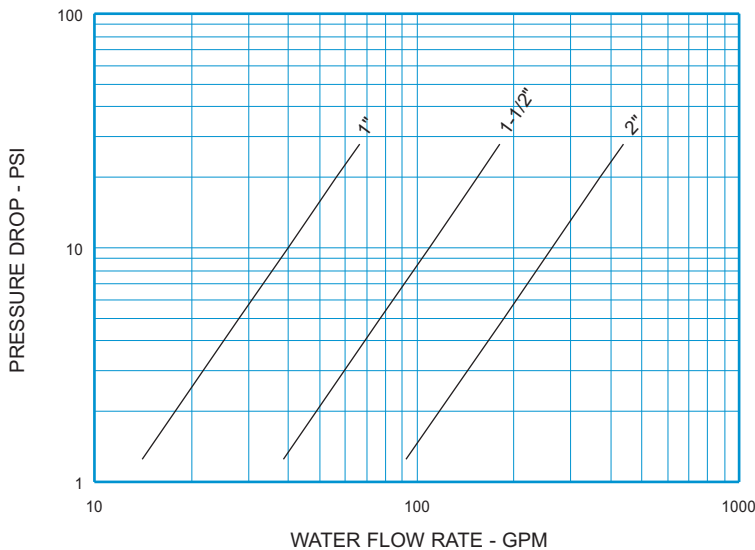

**Note:** All flow curves and Cv values presume the valves are fully open with 1/2 PSI cracking pressure springs. Consult the factory for more information.

STYLE HT C <sub>v</sub> VALUES & VALVE WEIGHTS		
C <sub>v</sub>	SIZE	PTFE LINED
12.6	1	3.7 lb.
34.5	1-1/2	5.8 lb.
83.0	2	9.4 lb.

See page 49 for Flow Formulae.  
Valve weights are approximate.

**HOW TO ORDER  
CHECK-ALL STYLE HT**

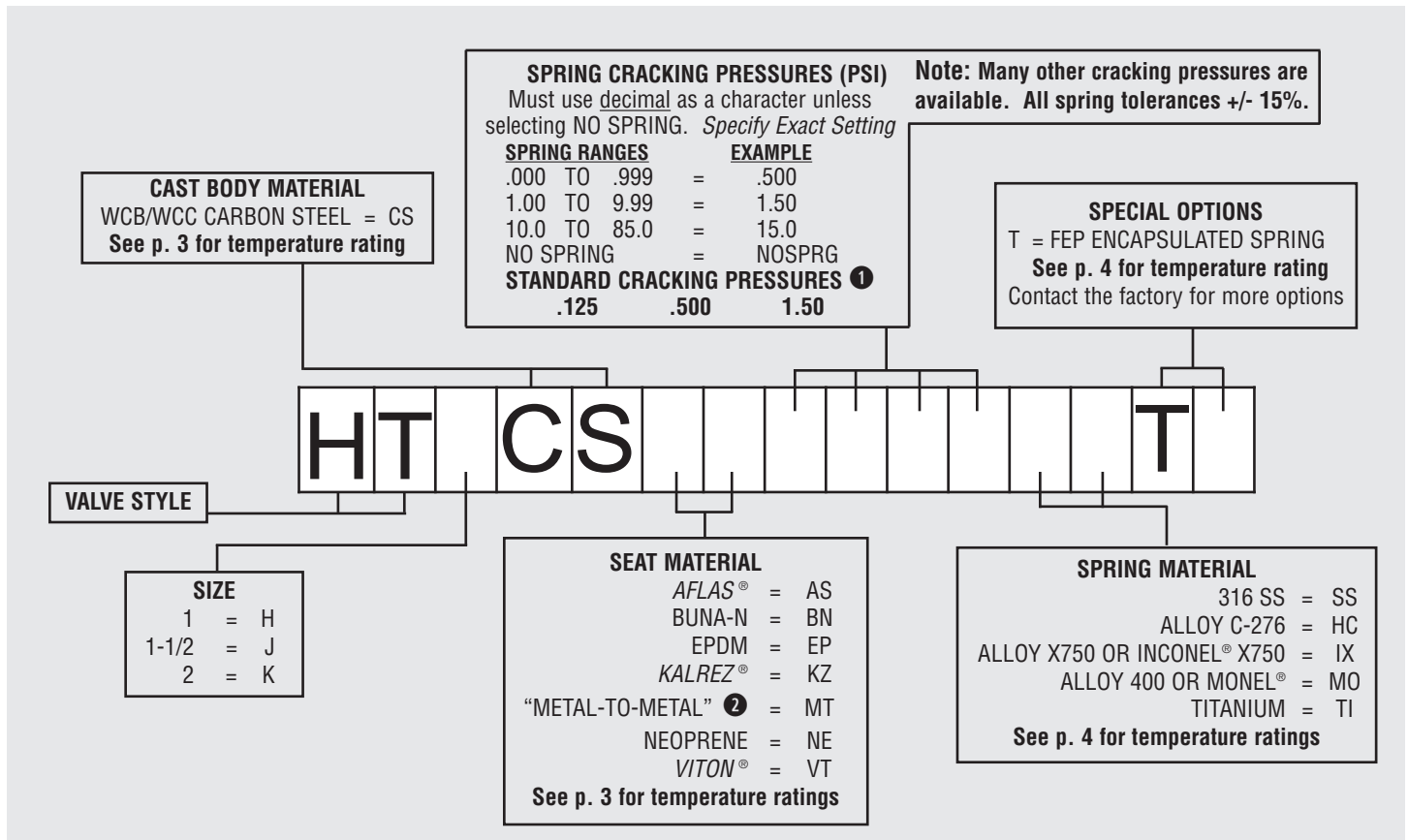

Listed above are the most common material selections. Please contact the factory for additional options.

① .500 PSI is the only standard cracking pressure for spring materials other than Stainless Steel. .125 PSI springs are not recommended for installations with flow vertical down.

② For PTFE lined valves, “MT” seats mean plastic to plastic. (No o-ring) See page 50 for allowable leakage rates.

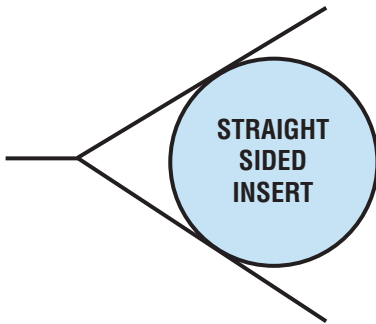

The **Straight Sided Insert (SI)** is a **threadless** check valve designed to be inserted into any cavity where a check valve is needed and threads are not desired. Consult the factory if your application requires tolerancing for a press fit installation. The SI valve can also be used as a low pressure relief valve or vacuum breaker by using the desired spring settings.

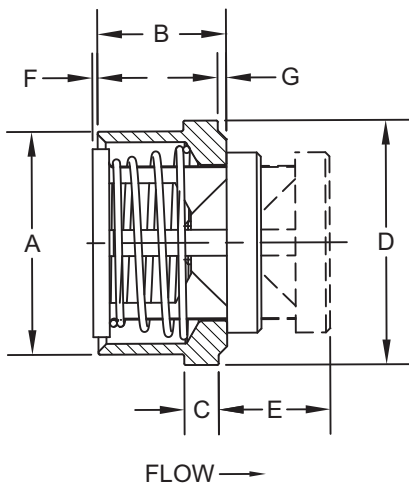

Nom. Pipe Size	Size Code	A	B	C	D	E <sup>1</sup>	F	G	Orifice Diameter
1/2	D	0.656	0.56	0.16	0.718	0.53	0.01	0.031	0.348
3/4	F	0.780	0.59	0.16	0.900	0.61	0.00	0.063	0.464
1	H	1.000	0.69	0.19	1.125	0.78	0.11	0.063	0.593
1-1/4	I	1.312	0.81	0.19	1.500	0.85	0.09	0.063	0.890
1-1/2	J	1.625	0.88	0.25	1.781	1.01	0.15	0.063	1.135
2	K	1.875	0.88	0.25	2.187	1.19	0.70	0.063	1.385

<sup>1</sup> Maximum nominal dimension for a fully open valve with no spring.

Body Material <sup>2</sup>	Availability	Non-Shock Pressure-Temperature Rating
316 Stainless Steel (SS)	Standard	3000 PSIG @ 100°F (1500 PSIG for o-ring seats)
Carbon Steel (CS)		
Brass (BR)		
Alloy 20 (A2)	Semi-standard	
Alloy C-276 (HC)		
Alloy 400 or Monel® (MO)		
Alloy B (HB)	Contact the factory for these or other materials.	
Titanium (TI)		

<sup>2</sup> See page 54 for material grade information.

**Straight Sided Insert**  
For Water at 72°F

**Note:** All flow curves and Cv values presume the valves are fully open with 1/2 PSI cracking pressure springs. Consult the factory for more information.

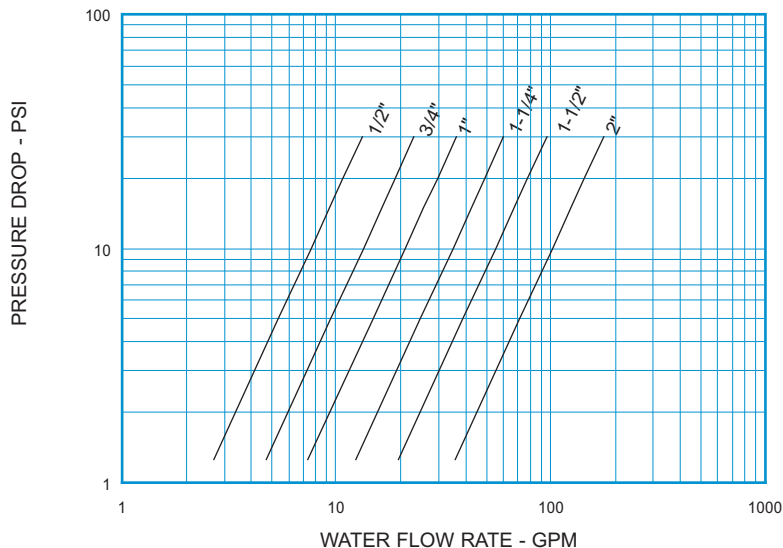

STYLE SI C <sub>v</sub> VALUES & VALVE WEIGHTS		
C <sub>v</sub>	SIZE	ALL MATERIALS
2.4	1/2	0.6 oz.
4.2	3/4	1.0 oz.
6.6	1	1.7 oz.
11.0	1-1/4	3.3 oz.
17.4	1-1/2	5.3 oz.
32.0	2	8.2 oz.

See page 49 for Flow Formulae.  
Valve weights are approximate.

**HOW TO ORDER  
CHECK-ALL STYLE SI**

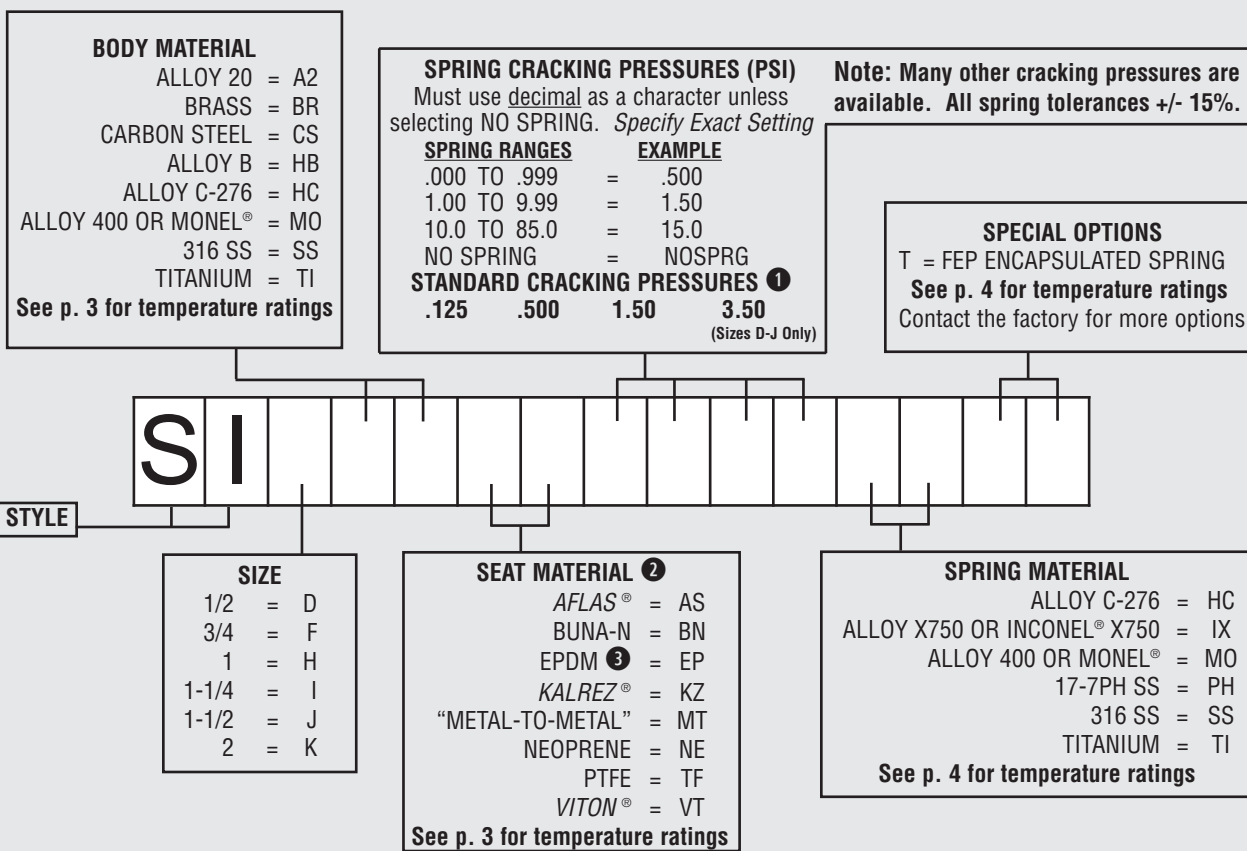

Listed above are the most common material selections. Please contact the factory for additional options.

- ① .500 PSI is the only standard cracking pressure for spring materials other than Stainless Steel. .125 PSI springs are not recommended for installations with flow vertical down.
- ② Seat materials other than "metal-to-metal" have a maximum pressure rating of 1500 PSI. "Metal-to-Metal" and PTFE seats are not resilient. See page 50 for allowable leakage rates.
- ③ EP seats not recommended for use with Carbon Steel valves.





See page 56  
Non-PED statement

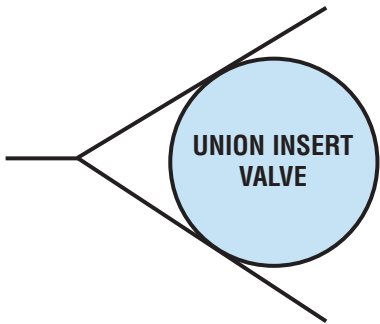

Union not included.

The **Union Insert (UV)** valve is the threaded pipe counterpart of the Flange Insert Valve. Designed to be inserted into most standard and hammer type ground joint unions, it provides the simplest and most economical way to install a check valve in a threaded pipe system. A check valve may be installed anywhere in the system where there is a union. The valve works equally well in either a horizontal or vertical position with proper spring selection. Each Union Insert valve is furnished with a **metal tag**, which is quickly attached to the union when the valve is installed. This provides a **permanent visual** notification that the union contains a check valve. The UV valve can also be used as a low pressure relief valve or vacuum breaker by using the desired spring settings.

**NOTE:** Bore of union must be equal to I.D. of schedule 40 pipe. Use ground joint unions with 45° seat only (union not included).

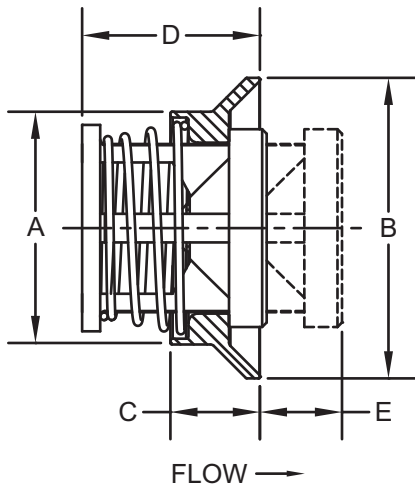

Nom. Pipe Size	Size Code	A	B	C	D	E <sup>1</sup>	Orifice Diameter
1/2	D	0.587	0.937	0.42	0.78	0.41	0.348
3/4	F	0.794	1.125	0.40	0.81	0.44	0.464
1	H	1.032	1.437	0.45	1.09	0.56	0.593
1-1/4	I	1.365	1.750	0.56	1.19	0.70	0.890
1-1/2	J	1.598	2.000	0.60	1.32	0.80	1.135
2	K	2.005	2.500	0.67	1.57	0.92	1.385

<sup>1</sup> Maximum nominal dimension for a fully open valve with no spring.

Body Material <sup>2</sup>	Availability	Non-Shock Pressure-Temperature Rating
316 Stainless Steel (SS)	Standard	3000 PSIG @ 100°F (1500 PSIG for o-ring seats)
Carbon Steel (CS)		
Brass (BR)		
Alloy 20 (A2)	Semi-standard	
Alloy C-276 (HC)		
Alloy 400 or Monel® (MO)	Contact the factory for these or other materials	
Alloy B (HB)		
Titanium (TI)		

<sup>2</sup> See page 54 for material grade information.

**Union Insert Valve**  
For Water at 72°F

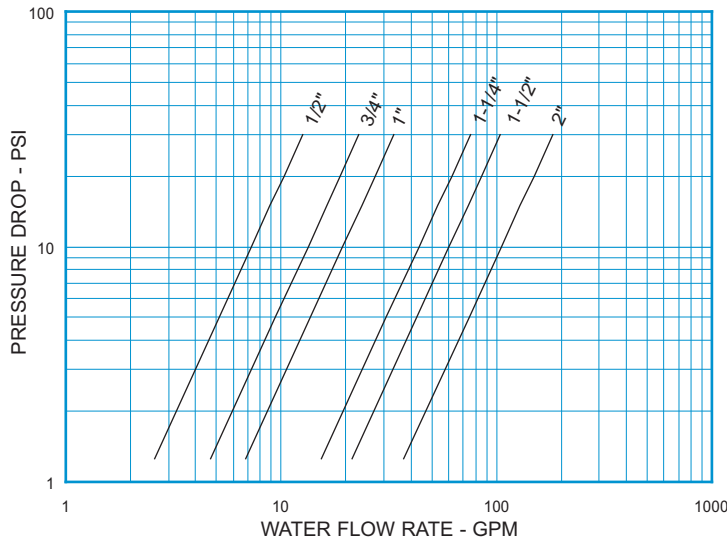

**Note:** All flow curves and Cv values presume the valves are fully open with 1/2 PSI cracking pressure springs. Consult the factory for more information.

STYLE UV C <sub>v</sub> VALUES & VALVE WEIGHTS		
C <sub>v</sub>	SIZE	ALL MATL
2.3	1/2	0.5 oz.
4.2	3/4	0.8 oz.
6.1	1	1.6 oz.
13.8	1-1/4	2.8 oz.
19.0	1-1/2	4.3 oz.
33.3	2	7.8 oz.

See page 49 for Flow Formulae.  
Valve weights are approximate.

**HOW TO ORDER  
CHECK-ALL STYLE UV**

**BODY MATERIAL**  
 ALLOY 20 = A2  
 BRASS = BR  
 CARBON STEEL = CS  
 ALLOY B = HB  
 ALLOY C-276 = HC  
 ALLOY 400 OR MONEL® = MO  
 316 SS = SS  
 TITANIUM = TI  
 See p. 3 for temperature ratings

**SPRING CRACKING PRESSURES (PSI)**  
 Must use decimal as a character unless selecting NO SPRING. *Specify Exact Setting*  
**SPRING RANGES**      **EXAMPLE**  
 .000 TO .999      =      .500  
 1.00 TO 9.99      =      1.50  
 10.0 TO 85.0      =      15.0  
 NO SPRING      =      NOSPRG  
**STANDARD CRACKING PRESSURES ①**  
 .125    .500    1.50    3.50  
 (Sizes D-J Only)

**Note:** Many other cracking pressures are available. All spring tolerances +/- 15%.

**SPECIAL OPTIONS**  
 T = FEP ENCAPSULATED SPRING  
 See p. 4 for temperature rating  
 Contact the factory for more options

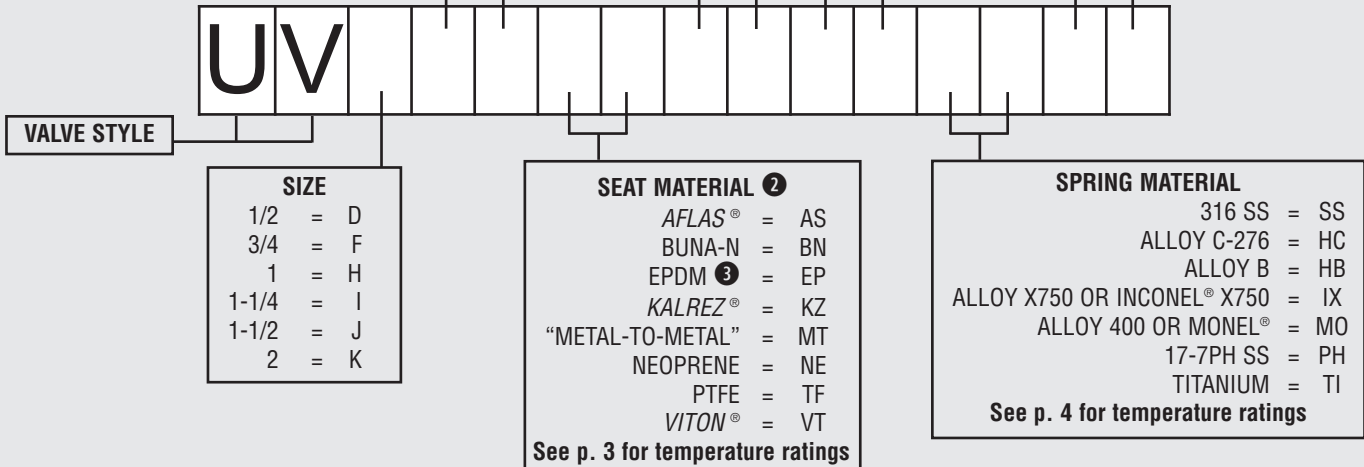

Listed above are the most common material selections. Please contact the factory for additional options.

- ① .500 PSI is the only standard cracking pressure for spring materials other than Stainless Steel. .125 PSI springs are not recommended for installations with flow vertical down.
- ② Seat materials other than “metal-to-metal” have a maximum pressure rating of 1500 PSI. “Metal-to-Metal” and PTFE seats are not resilient. See page 50 for allowable leakage rates.
- ③ EP seats not recommended for use with Carbon Steel valves.



**VALVES DESIGNED FOR  
YOUR APPLICATION NEEDS**

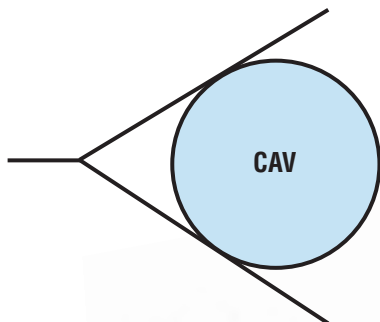

When a standard connection will not fit your application, the **CAV** check valve is made to meet your specific requirements, saving you time and money. Check-All® has extensive design experience to precisely connect to your unique application. Below is a small sample of some special designs we have made for our customers.

- ASME B16.5 Ring Type Joint
- AWWA C-606 Grooved Ends
- SAE J518 Code 61 & 62 Flange
- API 5CT Threaded Ends
- ISO 1609 Vacuum Flange (Insert)
- SAE J1926-1 Threaded Port
- ISO 6149-1 Threaded Port
- MIL MS33649 Threaded Port
- MIL MS16142 Threaded Port
- ASME B1.20.3 Dryseal Pipe Threads
- DIN Flanges
- Press Fit
- Cartridge Valve (outer o-ring seal)
- Tri-Clamp Ends

If you have a check valve application that is unique, contact our sales department to discuss your specific need.

# ADDITIONAL PRODUCTS AND SERVICES

## TAGGING AND MARKING:

**SS TAG:** Stainless steel plate with a stainless steel wire to be attached on or around the check valve after installation, for identification purposes. Customer supplied information marked on the plate.

**FLAG TAG:** Stainless steel plate with a stainless steel stem to be permanently attached for easy identification in applications where flange connections are used. Customer supplied information marked on the plate.

**PAPER TAG:** Card stock form of paper tag attached to the valve for identification purposes. Customer supplied information marked on the tag.

**VALVE MARKING:** Customer supplied information marked on the valve.

**MSS SP 25 MARKING:** Marking to provide information about the valve's pedigree and performance capabilities.

## VALVE CLEANING FOR THE FOLLOWING SERVICE APPLICATIONS:

Oxygen	Phosgene	Ethylene Oxide	Gas Phase Polyolefin
Chlorine	Isocyanate	Hydrogen Peroxide	

## VALVE TESTING/COMPLIANCE OPTIONS:

ASME B16.34	API 594	API 598	CPV (Cracking Pressure Verification)
Seat Leak	NACE	Hydro Shell	MSS SP 61/126
CE (PED of the European Union)			CRN (Canadian Registration Number)

## ADDITIONAL SERVICES:

Electropolishing	Passivation	Pickling	Bolted Trim
Drilled Hole in Trim	Spring Encapsulation		

# TECHNICAL DATA

**Valve Sizing** - Check-All® furnishes two methods to aid the customer in the selection of the correct valve size to meet their flow requirements; **Flow Curves and C<sub>v</sub> Factor**. Sizing accuracy requires the valve be fully open, which occurs when the pressure drop across the valve reaches or exceeds three times the spring cracking pressure (five times for 3S valves).

**Flow Curves** show the relationship between the rate of flow (water, gpm) and the pressure drop across the valve produced by that flow.

**C<sub>v</sub> Factor** is a valve flow coefficient which mathematically gives the relationship between the rate of flow and the pressure drop.

**Definition: C<sub>v</sub>** is defined as the quantity of 60° F water, in gallons per minute, which will pass through a specific valve at maximum lift, at one (1) psi pressure drop.

It is experimentally determined by dividing the water flow through the valve by the square root of the pressure drop produced by that flow. Conversely, given the C<sub>v</sub>, the water flow through the valve at any given pressure drop may be calculated by multiplying the C<sub>v</sub> by the square root of the pressure drop. Therefore, for a given pressure drop, the higher the C<sub>v</sub>, the higher the rate of flow.

For liquids other than water, for gases and for saturated steam, the formulae given below will show the relationship between the C<sub>v</sub> (as obtained from water flow tests) and the flow of these fluids.

## FLOW FORMULAE

(Non-Choked Turbulent Flow Only)

### I. LIQUIDS

$$V = C_v \sqrt{\frac{dP}{G}} \qquad dP = \left( \frac{V}{C_v} \right)^2 G \qquad C_v = \frac{V}{\sqrt{\frac{dP}{G}}}$$

Where:  $V$  = Liquid flow (gpm)  
 $dP$  = Pressure drop (psi)  
 $G$  = Specific Gravity of liquid (water = 1.0)  
 $C_v$  = Valve coefficient

### II. GASSES

$$Q = 1360 C_v \sqrt{\frac{dP}{GT}} \sqrt{\frac{P_1 + P_2}{2}} \qquad dP = P_1 - \sqrt{P_1^2 - 2GT \left( \frac{Q}{1360 C_v} \right)^2} \qquad C_v = \frac{Q}{1360 \sqrt{\frac{dP}{GT}} \sqrt{\frac{P_1 + P_2}{2}}}$$

Where:  $Q$  = Gas flow (scfh)  
 $dP$  = Pressure drop (psi)<sup>1</sup>  
 $T$  = Absolute temperature of flowing medium (degrees Rankine = °F + 460)  
 $P_1$  = Inlet pressure (psia)  
 $P_2$  = Outlet pressure (psia)  
 $C_v$  = Valve coefficient  
 $G$  = Specific Gravity of gas (air = 1.0)

### III. SATURATED STEAM

$$W = 3 C_v \sqrt{dP} \sqrt{\frac{P_1 + P_2}{2}} \qquad dP = P_1 - \sqrt{P_1^2 - 2 \left( \frac{W}{3 C_v} \right)^2} \qquad C_v = \frac{W}{3 \sqrt{dP} \sqrt{\frac{P_1 + P_2}{2}}}$$

Where:  $W$  = Saturated steam flow (lbs. per hour)  
 $dP$  = Pressure drop (psi)<sup>1</sup>  
 $P_1$  = Inlet pressure (psia)  
 $P_2$  = Outlet pressure (psia)  
 $C_v$  = Valve coefficient

1 - For calculation purposes, dP should never exceed 1/2 the inlet pressure, P<sub>1</sub>.

# Check-All Valve Application Guidelines

The following information is provided to assist in the selection of components when specifying or using Check-All Valve® products. It is presented for **general information only** and should not be considered an all-inclusive list, nor should it replace the on-sight process engineering required to properly apply any valve.

## Installation/Mounting

Check-All® valves can be used in horizontal or vertical applications with proper spring selection. This is most evident in vertical flow down installations. Minimum recommended net cracking pressure of 0.125 psi for most valves. The spring selected must be heavy enough in vertical flow down installations to support the weight of the trim in addition to any column of liquid desired to be retained. Consult the factory or your local Check-All Valve® representative for further information.

## Elbow, Tee or other Flow Skewing Device

Check-All® valves are best suited for use with fully developed flow. Although there are many factors affecting the achievement of fully developed flow (such as media, pipe roughness and velocity) usually 10 pipe diameters of straight pipe immediately upstream of the valve is sufficient. This is particularly important after flow skewing devices such as elbows, tees, centrifugal pumps, etc.

## Valve Material Selection

There are many factors that influence the resistance of materials to corrosion, such as temperature, concentration, aeration, contaminants and media interaction/reaction. Check-All Valve® will provide any assistance it can regarding the selection of products; however, the decision as to specific application of the valves and the materials of construction is beyond the scope of supply of Check-All Valve® products. This is the sole responsibility of the customer based upon his or her own evaluation.

## Seat Material Selection

Several seat material options are available for Check-All® valves. The allowable leakage rate associated with the “metal-to-metal” as well as the PTFE o-ring seat, is 188 cc/min per inch of line size, when tested with air at 80 PSI. Resilient o-ring seats are available for a “bubble tight” shut-off (no visible leakage allowed at 80 PSI air as defined by MSS SP-61). All o-ring seats are limited to a maximum operating pressure of 1500 PSI.

## Sizing and Spring Selection

Check-All Valve® recommends sizing check valves to ensure proper valve operation and service life. Valves can be sized using the equations on page 49. **Sizing accuracy requires the valve to be fully open, which occurs when the pressure drop across the valve reaches or exceeds three times the spring cracking pressure (five times for 3S valves).** Contact the factory or your local Check-All Valve® representative for further information or assistance.

## Shock-Load Applications

Check-All® valves are not designed for use in a shock-load environment, such as the discharge of a reciprocating air compressor. These types of applications produce excessive impact stresses which can adversely affect valve performance.

## Fluid Quality

Check-All® valves are best suited for clean, particle-free liquids or gasses. Debris such as sand or fibers can prevent the valve from sealing properly or it can erode internal components or otherwise adversely affect valve travel. These particles should be filtered out prior to entering the valves.

## Insert Series Valves

Check-All® Insert series valves such as the F1, F6, LP, UV, etc. are designed to use the existing pipe as part of the valve body. This provides a very cost effective solution for valve requirements. As such, part of the valve functions inside the existing pipe; therefore, dimensional clearance must be maintained for proper valve operation. See the pertinent catalog pages or contact the factory or your local Check-All® representative for more information.



**INSTALLATION AND OPERATING INSTRUCTIONS**

**WARNING!!!** READ ALL OF THESE INSTRUCTIONS BEFORE PROCEEDING. ONLY EXPERIENCED PERSONNEL SHOULD BE ALLOWED TO INSTALL OR HANDLE THE ENCLOSED VALVE(S). ANY DAMAGE RESULTING FROM MISHANDLING OR IMPROPER INSTALLATION IS NOT COVERED BY THE MANUFACTURER'S WARRANTY. FOR WARRANTY DETAILS, REFER TO THE LATEST REVISION OF CHECK-ALL VALVE® MANUFACTURING COMPANY MANUFACTURER'S TERMS AND CONDITIONS ([Form #160](#)).

The following instructions are meant as a guideline only. They do not cover every situation and rely on the common sense and expertise of the person installing the valve. In no way is Check-All® liable for any damage to the valve, the system, or for personal injury resulting from use of these guidelines.

**GENERAL INSTRUCTIONS**

- **Inspection.** Prior to installation, inspect valves for any damage. Refer to Check-All Valve® Terms and Conditions [Form #160](#) for warranty information.
- **Flow arrows.** Install each check valve in the line with the arrow pointing in the direction of the flow. To verify proper installation, make sure each valve opens in the direction of desired flow. Note: From the closed position the poppet moves away from the seat in the direction of flow.
- **Valve support.** Valves must be adequately supported with pipe hangers, etc. to prevent additional loading on the valve body.
- **Alignment & connection.** Refer to ASME B31 "Pressure Piping Code" and ASME PCC-1 "Guidelines for Pressure Boundary Bolted Flange Joint Assembly" for recommended guidelines on alignment, bolt torque, etc.
- **Safe connection.** Valves must be adequately connected (threaded, welded, etc.) to surrounding piping to prevent unsafe discharge during filling and/or operation.
- **Insert series valves.** Insert series valves may not be visible after installation. It is the end user's responsibility to verify that there is adequate identification of the presence of a check valve that is installed in the system and to take any necessary precautions to avoid injuries or spills when the line is disassembled for maintenance or other reasons. Please consult the factory or your [local Check-All representative](#) for tagging options or further information.
- **Intended Use.** Valves compliant with the European Union Pressure Equipment Directive (2014/68/EU) that have been classified under Sound Engineering Practice may be limited in their use. They will be identified as such with either marking on the valve body or an additional tag. If such classification is marked on an additional tag it is the end-users responsibility to reattach such identification to the installed valve or surrounding piping.

**THREADED VALVES: (BU, BR), (CN, CR), (U3, UR), (U1, R1), AND (M1-M8)**

Handle threads on these valves carefully to avoid damage. Use an anti-seize thread sealant to prevent galling. Note: Because Bushing Series (BU) valves open into downstream connections, ensure adequate clearance for the travel of the poppet.

**VALVES WITH TUBING CONNECTIONS: (TV), (TF) and (M5-M8)**

For a valve with flared fittings, slide the nut (not provided with the valve) onto the tubing and flare the tubing end. Tighten the nut onto the flared end of the valve. Note: Leakage can result if the flared surface is damaged. For a valve with compression fittings, first slide the nut on the tubing then the ferrule. Next, insert the tubing end into the valve fitting and tighten the nut. Note: The fittings are supplied as accessories only, and as such are not governed by the European Union Pressure Equipment Directive 2014/68/EU.

**FLANGED END VALVES: (HV)**

Install each valve between ANSI class 150 raised face flanges with a gasket between each flanged joint and tighten the bolts per gasket manufacturer's torque recommendations.

**FLANGED END LINED VALVES: (HT)**

Install each valve between ANSI class 150 raised face flanges (no gaskets are necessary) and tighten the bolts only enough to ensure no leakage. Note: The valve liner may be damaged by over-tightening the bolts and/or by piping systems that add additional loads to the flanged joints.

**FLANGE, LINED PIPE and WAFER INSERT VALVES: (F1, F6, FP, FR), (LP) and (WV)**

Make sure the piping inside diameter is adequate because this type of valve extends into upstream and downstream piping. Additionally, make sure there are no obstructions that would disrupt fluid flow or interfere with poppet travel. Install each valve between ANSI raised face flanges with a gasket on each side of the valve (PTFE valves need no gaskets). Ensure that each valve is centered inside the bolt circle and tighten the bolts. Note: Plastic material valves can be damaged by over tightening the bolts and by piping systems that add additional loads to valve flanged joints. If a flag tag with a flow arrow is attached to the valve, the tag shall not be rotated or removed so that the flow arrow on the tag remains accurate.

**SANITARY INSERT VALVES: (CB, TC)**

Verify that ferrules (CB and TC) are correct for each valve to be installed by comparing the fit between the two. If the fit is correct, center the valve in the ferrules and tighten the clamp. A valve can be damaged by misalignment, by over tightening, and by piping system loads that affect the joint that contains the valve.

**SANITARY CARTRIDGE VALVES: (3S) AND (SC)**

The inside diameter of the sanitary tubing must be the size listed in the catalog description of the valve. Lubricate the body o-rings, push the valve into the piping and then secure the clamp or nut. Note: A valve may leak if piping is misaligned. Also refer to "3S Disassembly For Cleaning Instructions" ([Form #152](#)) and "SC Installation Instructions" ([Form #157](#)). See [www.checkall.com](http://www.checkall.com) or request a copy from the factory.

**UNION INSERT VALVES: (UV)**

Note that the union the UV is installed into must have a 45° seat and the ID must be equal to the ID of schedule 40 pipe. Center each valve in the union so the angles match and tighten the union nut enough to seal. Attach the metal identification tag to the union according to its instruction sheet.

**STRAIGHT-SIDED INSERT VALVES: (SI)**

This series is designed to fit in a designed cavity. Note: Forcing a valve into a cavity could cause the seat to deflect or warp and cause leakage.

**UNIVERSAL SOCKET WELD AND BUTT WELD VALVES: (US) AND (B4, B8)**

These series are designed to weld into a system. When welding, use standard welding procedures and safety precautions. A material data safety sheet for the body material will be provided upon request. **WARNING:** A valve can be damaged by excessive heat that may warp or melt the seat and cause it to leak. Use a heat sink or other means to prevent valve damage from occurring.

**MAINTENANCE & INSPECTION:**

- ◇ Corrosive media. For valves installed in corrosive media, Check-All® recommends establishing inspection schedules to ensure the continued safe use of the valve.
- ◇ Depressurization & draining. To avoid potential hazards due to discharge, depressurize and drain the surrounding system prior to removing the valve from the system.
- ◇ Surface temperature. To avoid personal injury, do not touch surface of valves if the media within is colder or hotter than room temperature. Allow the valve to return to room temperature prior to removing from the system.
- ◇ Valve inspection. For applications that necessitate periodic valve inspection, Check-All® can provide, upon request, the critical pressure boundary dimensions of valve bodies. Maintenance or other qualified personnel should also visually inspect the valves for signs of wear that could adversely affect valve performance.
- ◇ Cleaning. Care should be exercised when cleaning valves (with steam, chemicals, etc) to protect them against excessive pressure, temperature, and/or corrosion.
- ◇ Field repair. Check-All® does not recommend field repair for any valve, except the 3S series. If field repair is absolutely necessary contact the factory or the local representative for instructions. A defective valve may be returned to the factory and MUST be accompanied by a completed and signed Return Material Authorization.

**HAZARDS & DAMAGE DUE TO MISUSE:**

- Installation next to an “ell”. Do not install the valve next to the discharge of an elbow “ell” or directly after any component that could alter or disrupt the flow pattern. Check-All® valves are best suited for use with fully developed flow. Although there are many factors affecting the achievement of fully developed flow (such as media, pipe roughness and velocity), usually (10) pipe diameters of straight pipe immediately upstream of the valve is sufficient. This is particularly important after flow skewing devices such as elbows, tees, centrifugal pumps, etc.
- Shock-load applications. Do not install the valve on the discharge of a reciprocating compressor or any other element that will cause a physical and/or thermal shock-load.
- Pressure limit. Maximum allowed room temperature pressure rating is shown on the pertinent catalog pages. In the case of valves ordered with CE marks or registered in Canada (CRN), the room temperature pressure rating is marked on the valve or flag tag supplied. Over-pressurization (due to fluid heating, chemical reaction, explosion, external fire, etc) can cause failure of the valve body and/or the valve internals; therefore, other means must be taken in the surrounding system to prevent this.
- Additional loads & considerations. Pressure ratings are based on internal pressure only. Additional loadings (environmental, head pressure, line-loads, etc) on valves must be accounted for by the end-user. Valve weights are listed in the Check-All® catalog or at [www.checkall.com](http://www.checkall.com).
- Temperature limits. Allowable operating temperature limits are shown in the catalog. In the case of valves ordered with CE marks, the limitations are marked on the valve body or accompanying flag tag. Temperatures higher or lower (due to the media, chemical reactions, environmental, conduction, convection, etc) than those allowed can cause failure of the valve body and/or internals. Contact Check-All® for temperature range information and reduced pressure ratings at elevated temperatures.
- Corrosive applications. Corrosion allowances are available upon request for all valves. It is the end-users responsibility to determine the suitability of the valve material for the internal and external environment in which it is used, as well as to establish inspection schedules. Refer to the latest revision of [Form #180](#) “Body Material Definition for Check-All® Valve Products” to determine from what material valve bodies are made. Where the possibility of condensation of gaseous fluids exists, external means in the surrounding system may need to be provided for drainage and removal of deposits from low areas to avoid damage from corrosion. Carbon steel valves are supplied with an oil coating but are not plated.
- Media debris, leakage, & erosion. Check-All® valves are best suited for clean, particle-free liquids or gases. Debris such as sand or fibers can prevent the valve from sealing properly, erode the body and/or internal components, or otherwise adversely affect valve travel. These particles should be filtered out prior to entering the valves.
- Valve sizing. Proper operation requires correct valve sizing. If valves are oversized for the operating conditions, trim can chatter and cause excessive wear to the entire valve. Sizing accuracy requires the valve be fully open which occurs when the pressure drop across the valve reaches or exceeds approximately three times the spring cracking pressure (five times for 3S series). If valves are undersized, pressure drop may be excessive and cause the o-ring to come out of the groove. Valves can be sized using the equations or flow charts located in the Check-All® catalog or the Flow Data section of the Check-All® website [www.checkall.com](http://www.checkall.com). Contact the factory, [sales@checkall.com](mailto:sales@checkall.com), or [your local Check-All representative](#) for further information or assistance.
- Seat leakage. PTFE o-rings, plastic-to-plastic seats and metal-to-metal seats are not necessarily “bubble tight”. Allowable leakage rates are listed in the Check-All® catalog or at [www.checkall.com](http://www.checkall.com) in the [Application Guidelines](#) section.
- Decomposition of unstable media. Check-All® valves are not designed to withstand excessive temperature and/or pressure beyond their marked limits due to the decomposition of unstable media.
- Fatigue life. CE marked valve bodies have been evaluated using the ASME Boiler and Pressure Vessel Code latest revision or material manufacturer literature.
- Safety accessory. Valves are not to be used as safety accessories as defined in the [Pressure Equipment Directive \(PED\) 2014/68/EU](#).
- External fire. Any risk arising from external fire must be accounted for in the surrounding system.
- Galvanic reactions. Suitability of the valve body material when connected with the surrounding piping material is the sole responsibility of the end-user. Galvanic reactions can lead to material loss that can lead to failure of the pressure boundary. Refer to [Form #180](#) “Body Material Definition for Check-All Valve® Products” to determine from what material valve bodies are made.

Check-All Valve® Mfg. Co. seeks for the highest level of quality and performance in its products. If you have comments regarding its products, the instructions, require documents referred herein, or need further assistance, please contact your local representative or:

**Check-All Valve Mfg. Co.**  
 1800 Fuller Road  
 West Des Moines, IA 50265 U.S.A.  
 Phone: 515-224-2301 – Fax: 515-224-2326  
 Website: [www.checkall.com](http://www.checkall.com) – Email: [sales@checkall.com](mailto:sales@checkall.com)

# Body Material Definition for Check-All® Valve Products

To determine the specific material definition, use the following procedure. This grid is the typical designation of body materials. Slight variations may occur due to raw material availability.

- 1) Note the material designation imprinted on the valve body or associated tag. The marking includes the valve style, size letter and body material. Some examples include:
  - a) F1: F1JSS this means the size is 1-1/2" NPS (J = 1-1/2"), the style is F1 (Flange Insert Valve), it is designed for ANSI class 150 or 300 flanges, or similar and schedule 40 or lighter pipe and the body material code is SS.
  - b) U3: U3JSS this means the style is U3, the size is 1-1/2" NPS (J = 1-1/2", K = 2", etc.) and the body material code is SS.
- 2) Now check the material code in the valve marking in the following material definition table to determine the ASTM (American Society of Testing and Materials) material designation. The style size and material code will be needed to define the material. In general, the material codes are as follows:

A2 - Alloy 20	HB - Alloy B	PV - PVC
BR - Brass or Bronze	HC - Alloy C-276	SS - 316 Stainless Steel
CS - Carbon Steel	MO - Alloy 400 or MONEL®	TF - PTFE
		TI - Titanium

**NOTE:** The table below designates the material by valve body style and size range. Cast materials are shaded gray.

BAR MATERIALS		CAST MATERIALS																			
STYLE	SIZE RANGE	A2	BR	CS	CS	HB	HC	MO	PV	SS	TF	TI	A2	BR	CS	HB	HC	MO	SS	TI	
3S	H - N (1" - 4")									•											
B4 B8	D - N (1/2" - 4")	•			•	•	•	•		•											
BU BR	D - M (1/2" x 3/8" to 3" x 2-1/2")	•	•	•		•	•	•		•		•									
CN CR	D - N (1/2" - 4")	•	•	•		•	•	•		•		•									
F1 F6	D - I (1/2" - 1-1/4")	•		•		•	•	•		•		•									
F1	D - J (1/2" - 1-1/2")		•									•									
F1	J - W (1-1/2" - 20")												•		•	•	•	•	•	•	•
F1	K - W (2" - 20")													•							

BAR MATERIALS								CAST MATERIALS													
ASTM D1710 Type 1, Grade 1, Class A or B PTFE ASTM A479 Gr. 316/316L (S31600/S31603) ISO 1163-PVC-U, ED, 078-05-33 ASTM B164 (N04400 or N04405) ASTM B574 (N10276) ASTM B335 (N10665 or N10675) ASTM A108 Gr. 1018 (G10180) ASTM A108 Gr. 1215 (G12150) ASTM B16 H02 TEMPER (C36000) ASTM B473 (N08020)								ASTM B367 Gr. C-3 (R50550) ASTM A351 Gr. CF8M (J92900) ASTM A494 Gr. CW72MW (N30002) ASTM A494 Gr. M-35-2 (N04020) ASTM A216 Gr. N7M (N30007) ASTM B062 (C83600) ASTM CN7M (N08007) ASTM B062 (C83600) ASTM A494 Gr. CW72MW (N30002) ASTM A494 Gr. M-35-2 (N04020)													
STYLE	SIZE RANGE	A2	BR	CS	CS	HB	HC	MO	PV	SS	TF	TI	A2	BR	CS	HB	HC	MO	SS	TI	
F6	J - N (1-1/2" - 4")												•		•	•	•	•	•	•	•
FP	D - P (1/2" - 6")								•		•										
HV	H - R (1" - 10")														•					•	
HT	H - K (1" - 2")										LINER				•						
LP	H (1")						•					•									
LP	J - M (1-1/2" - 3")											•					•				
M1 - M8	A - C (1/8" - 3/8")	•	•	•		•	•	•		•											
SC	F - N (3/4" - 4")									•											
CB TC	F - N (3/4" - 4")											•									
SI	D - K (1/2" - 2")	•	•	•		•	•	•		•		•									
TV	A - K (1/8" - 2")		•	•						•											
TF	A - K (1/8" - 2")		•	•						•											
UV	D - K (1/2" - 2")	•	•	•		•	•	•		•		•									
U1 R1	C - J (3/8" - 1-1/2")	•		•		•	•	•		•		•									
U3 UR	C - N (3/8" - 4")	•	•	•		•	•	•		•		•									
US	C - N (3/8" - 4")	•			•	•	•	•		•		•									
WV	D - N (1/2" - 4")	•	•	•		•	•	•		•		•									

Other valve materials are available. If you have a valve made of another material, please consult the factory for the material identification. Please supply the style, size and material code of the valve when contacting the factory.

**Check-All Valve® Mfg. Co.** – 1800 Fuller Road – West Des Moines, IA 50265 U.S.A.  
 Phone: 515-224-2301 – Fax: 515-224-2326 – Website: [www.checkall.com](http://www.checkall.com) – Email: [sales@checkall.com](mailto:sales@checkall.com)

## Pressure Equipment Directive (PED 2014/68/EU) Conformance

All Check-All® valves conform to the Pressure Equipment Directive (PED 2014/68/EU). In order for pressure equipment products such as check valves to be placed on the open market in the European Community, they must comply with this law.

Due to the flexibility of the PED, some valves may require them to be CE marked while the identical valve, in another application, may not require a CE mark. Prior to ordering a PED valve, it must be classified using the PED Annex II Conformity Assessment Tables 6, 7, 8, & 9 (see tables below). Information necessary when using the tables are the valve size, pressure rating, media type (gas or liquid) and the danger presented by the media (Group 1 or Group 2). Note when using the PED tables, Article 4 paragraph 3 of the PED is commonly referred to as Sound Engineering Practice (SEP). Please note Check-All® valves are not to be used as safety accessories as defined in the Pressure Equipment Directive (PED 2014/68/EU).

For further information on the PED refer to the European Commission's PED website at [http://ec.europa.eu/growth/sectors/pressure-gas/pressure-equipment/directive\\_en](http://ec.europa.eu/growth/sectors/pressure-gas/pressure-equipment/directive_en) or consult the factory for assistance. For assistance with classifying the media as Group 1 or Group 2, refer to Article 13 of Directive 2014/68/EU.

**If the ultimate destination of this product is to the European Economic Union, please indicate this as such at the time of the inquiry so the necessary arrangements can be made.**

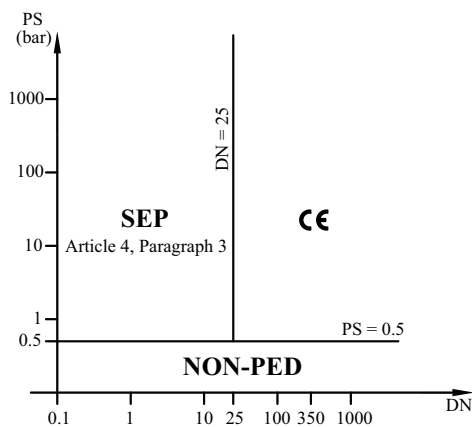

Table 6  
Piping Containing a Group 1 Fluid

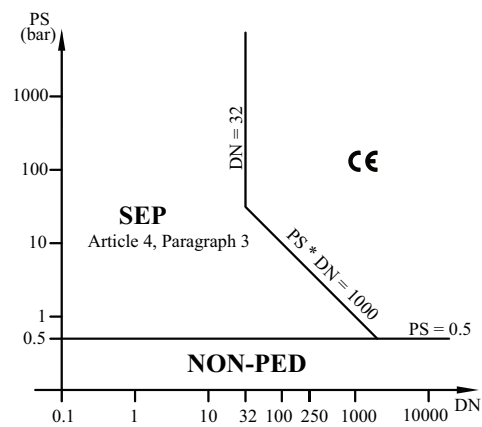

Table 7  
Piping Containing a Group 2 Fluid

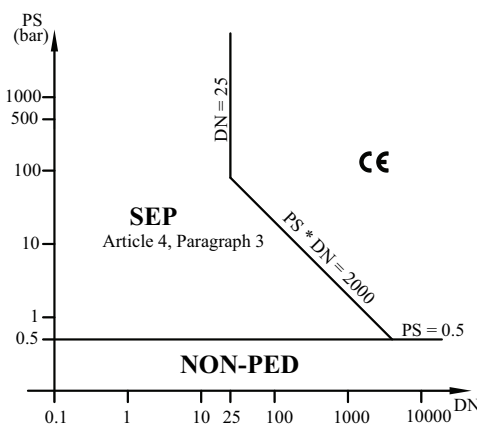

Table 8  
Piping Containing a Group 1 Fluid

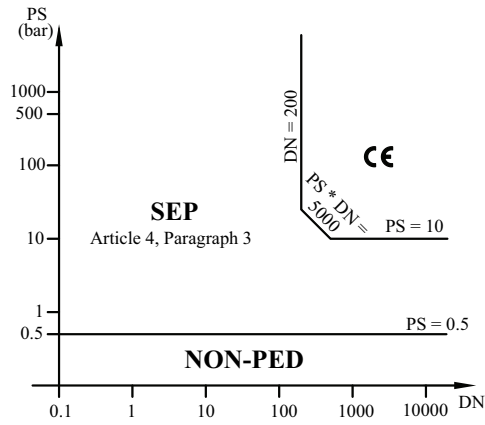

Table 9  
Piping Containing a Group 2 Fluid

## NON-PED Valves

Some valve styles or valves used at certain operating conditions do not fall under the scope of the PED. These valves are supplied as “NON-PED” valves.

Due to the unique “insert” design of our **3S, SC, CB, TC, SI, & UV** style check valves, they do not constitute an “identifiable pressure bearing housing” as defined in PED Guideline A-08. These styles must be installed into either ferrules or fittings to create a pressure-bearing housing. Instead, they are classified as “components of pressure equipment” as defined in PED Guideline A-08. As a result, these valves can be sold in the European Community and no CE Mark is required.

In addition applications where the maximum allowed operating pressure is 0.5 bar (7.2 psi) or less, do not fall under the PED, regardless of the valve style.



# ORDER FORM



**1800 FULLER ROAD  
WEST DES MOINES, IA 50265  
Phone: 515-224-2301  
Fax: 515-224-2326  
E-mail: sales@checkall.com**

Also available online at

[www.checkall.com](http://www.checkall.com) - Order Information

\* PAGE: \_\_\_\_\_ OF \_\_\_\_\_

\* DATE/TIME: \_\_\_\_\_

\* CONTACT NAME: \_\_\_\_\_

\* PHONE #: \_\_\_\_\_

\* Required fields

Check-All Quote Number: \_\_\_\_\_

\* Acknowledgment should be sent to: **Fax/E-mail:** \_\_\_\_\_

INVOICE INFORMATION	
* PO:	_____
* COMPANY NAME:	_____
* ADDRESS	_____
* CITY	* STATE/PROV. * POSTAL CODE
COUNTRY	_____
* REQUESTED SHIP DATE	_____

SHIPPING INFORMATION	
* PO:	_____
* COMPANY NAME:	_____
ADDRESS	_____
CITY	STATE/PROV. POSTAL CODE
COUNTRY	* SHIP VIA
SPECIAL INSTRUCTIONS	_____

LINE ITEMS			
QTY	CAV PART NUMBER	UNIT COST	ADDITIONAL INFO

### COMMENTS

<p>_____</p> <p>_____</p>
---------------------------

**THANK YOU FOR YOUR ORDER**

Form#117D

## Copy of Manufacturer's Terms and Conditions of Sale

**1. CONSTRUCTION AND LEGAL EFFECT:** Except as otherwise specifically agreed in writing, our sale to you is limited to and expressly made conditional on your assent to the written terms and conditions of sale on the face and reverse side hereof, all of which form a part of this order and which supercede and reject all prior writings, representations, negotiations with respect hereto and any conflicting terms and conditions of yours, any statement therein to the contrary notwithstanding. The sending of the purchase order for the goods referred to herein, whether or not signed by you, or your acceptance of the goods or payment operates as acceptance by you of our terms and conditions of sale. We will furnish only the quantities and goods specifically listed on the face hereof or the pages attached hereto. We assume no responsibility to terms or conditions or for furnishing other equipment or material shown in any plans and/or specifications for a project to which the goods quoted or ordered herein pertain or refer. Our published or quoted terms and conditions are subject to change without notice.

**2. PRICES:** Unless otherwise noted on the face hereof, prices are net, FOB carrier, our factory. Stenographic, clerical and mathematical errors are subject to correction. Until order is accepted by us, quoted prices are subject to change without notice.

**3. DELIVERY:** Dates for the furnishing of services and/or delivery or shipment of goods are approximate only and are subject to change. Quoted lead times are figured from the date of receipt of complete technical data and approved drawings as such may be necessary. We shall not be liable, directly or indirectly, for any delay in or failure to deliver caused by carriers or delays from labor difficulties, shortages, strikes or stoppages of any sort, failure or delay in obtaining materials from ordinary sources, fires, floods, storms, accidents, causes designated acts of God or force majeure by any statute or court of law or other causes beyond our reasonable control. In no event shall we be liable for any damages or penalties whatsoever, whether direct, indirect, special or consequential, resulting from our failure to perform or delay in performing.

**4. SHORTAGES, DAMAGE AND ERRORS IN SHIPMENT:** Our responsibility ceases upon delivery to carrier. Risk of loss, injury or destruction of property, shall be borne by you, and such loss, injury or destruction of property shall not release you from payment of purchase price. You shall note receipt for goods that are not in accordance with bill of lading or express receipt without proper notation to the carrier, and you shall make claim against such carrier for any shortage, damage or discrepancy in the shipment promptly. All claims of shortage of discrepancies associated with the manufacturer must be reported within 14 days of receipt of shipment. You shall inspect and examine all items and goods covered by the order when unpacking crated or boxed goods, and if damage is discovered, leave as is until the carrier's agent makes examination and notation on freight or express bill of concealed damage. We will render assistance to help trace and recover lost goods and collect just claims as a business courtesy, but without obligation. We do not guarantee safe delivery.

**5. TAXES:** Our prices do not include sales, use, excise, occupation, processing, transportation or other similar taxes which we may be required to pay or collect with respect to any of the materials covered hereby under the existing or future law. Consequently, in addition to the price specified herein, such taxes shall be paid by you, or you shall provide us with a tax exemption certificate acceptable to the appropriate taxing authorities. You shall also assume and pay any import or export duties, with respect to the materials covered by the order, and shall save us harmless there from.

**6. CREDIT AND PAYMENT:** Unless otherwise noted on the face hereof, payment of goods shall be (30) days net. Prorate payments shall become due with partial shipments. We reserve the right at any time to suspend credit or to change credit terms provided herein, when, in our sole opinion, your financial condition so warrants. Failure to pay invoices at maturity date, at our election, makes all subsequent invoices immediately due and payable irrespective of terms, and we may withhold all subsequent deliveries until the full account is settled and we shall not, in such event, be liable for non-performance of contract in whole or in part.

**7. DOCUMENTS:** Unless otherwise agreed to in writing, all documents furnished shall be in the English language.

**8. TECHNICAL DOCUMENTS AVAILABILITY:** Check-All Valve® Mfg. Co. will supply technical documents to competent governmental authorities upon request as required by law.

**9. CANCELLATIONS AND CHANGES:** Orders which have been accepted by us are not subject to cancellation or changes in specifications; except upon our written consent, and we may require as a

condition of such consent, reimbursement for any cost incurred in performance in accordance with the order in original form.

**10. DEFERRED SHIPMENT:** If shipment is deferred at your request, payment of the contract price shall become due when you are notified that the valves are ready for shipment. If you fail to make payment and furnish shipping instructions, we may either extend time for so doing or cancel contract. In case of deferred shipment at your request, storage and other reasonable expenses attributable to such delay shall be payable by you.

**11. WARRANTY:** Check-All Valve® Mfg. Co., hereinafter called "Check-All®" warrants as follows:

- (a) That each new Check-All® valve is free from defects in material and workmanship when installed and used in accordance with current Check-All® publications. Customer modified valves may void warranty.
- (b) That each new Check-All® valve is fit for the purpose for which similar type valves are ordinarily intended. Purchaser shall be solely responsible for determining suitability for use and in no event shall Check-All® be liable in this respect.

**DURATION**—The warranty period shall begin on the date of shipment to the first purchaser and extend for twelve (12) months.

**EXCLUSIVE REMEDY**—Check-All® will repair or replace at its discretion, any valve it finds to be defective under this warranty, upon return of the valve, prepaid, to Check-All® at 1800 Fuller Road, West Des Moines, IA 50265 or any warehouse designated by Check-All®. Except for such repairs or replacements, **CHECK-ALL® SHALL NOT BE LIABLE FOR CONSEQUENTIAL DAMAGES RESULTING FROM BREACH OF THIS WRITTEN WARRANTY OR ANY IMPLIED WARRANTY.**

**DISCLAIMER**—Check-All® excludes from this warranty compressor discharge applications; valves mounted on the discharge of an elbow ("ell"); and failures due to corrosion, erosion, abrasion, cavitation, or other application-related failures and **DISCLAIMS ANY EXPRESS OR IMPLIED WARRANTY OF FITNESS FOR A PARTICULAR PURPOSE.** Further, it is the end user's responsibility to account for environmental influences such as traffic, wind, earthquake or other external loadings, decomposition of unstable fluids, simultaneous loadings or loadings due to fluid weight. There are no warranties that extend beyond the terms hereof and no one is authorized to assume for Check-All® any other liability in connection with the sale of Check-All® valves. This warranty supercedes all previous warranties.

**12. LIMITATION OF LIABILITY:** IN NO EVENT SHALL CHECK-ALL® BE LIABLE FOR ANY DIRECT, INDIRECT, SPECIAL OR CONSEQUENTIAL DAMAGES WHATSOEVER, AND CHECK-ALL'S LIABILITY, UNDER NO CIRCUMSTANCES, WILL EXCEED THE CONTRACT PRICE FOR THE GOODS AND/OR SERVICES FOR WHICH LIABILITY IS CLAIMED. ANY ACTION FOR BREACH OF CONTRACT MUST BE COMMENCED WITHIN 1 YEAR AFTER THE CAUSE OF ACTION HAS OCCURRED.

**13. EUROPEAN UNION:** For purposes of defining Check-All Valve® products according to the Pressure Equipment Directive, 97/23/EC, these valves are not intended for use as the sole means of isolation.

**14. TEXAS:** Buyers who are business consumers as described in section 17.42 of the Texas Deceptive Trade Practices Act (the "DTPA") waive all provisions of the DTPA to the fullest extent allowed by the DTPA.

**15. APPLICABLE LAW:** The rights and duties of the parties shall be governed by the laws of the State of Iowa.

**16. NO OTHER CONTRACT PROVISIONS:** Except as otherwise previously and specifically agreed in writing by the parties, terms and conditions of your order shall be without force and effect, except as they are identical herewith. No dealer, broker, branch manager, agent, employee or representative of ours has any power or authority except to take orders for our products and to submit the same to us, at our factory, for our approval and acceptance or rejection. There are no representations, agreements, obligations, or conditions, expressed or implied, statutory or otherwise, relating to the subject matter hereof, other than herein contained, and these terms and conditions shall be incorporated in and become a part of any agreement between the parties with reference to purchase of our products.

**17. USER RESPONSIBILITY:** It is the sole responsibility of the end user to comply with all applicable federal, states, provincial, and local laws and regulations.

# WARRANTY

Check-All Valve® Mfg. Co., hereinafter called "Check-All" warrants as follows:

- (a) That each new Check-All® valve is free from defects in material and workmanship when installed and used in accordance with current Check-All® publications. Customer modified valves may void warranty
- (b) That each new Check-All® valve is fit for the purpose for which similar type valves are ordinarily intended. Purchaser shall be solely responsible for determining suitability for use and in no event shall Check-All® be liable in this respect.

**DURATION**—The warranty period shall begin on the date of shipment to the first purchaser and extend for twelve (12) months.

**EXCLUSIVE REMEDY**—Check-All® will repair or replace at its discretion, any valve it finds to be defective under this warranty, upon return of the valve, prepaid, to Check-All® at 1800 Fuller Road, West Des Moines, IA 50265 or any warehouse designated by Check-All®. Except for such repairs or replacements, CHECK-ALL® SHALL NOT BE LIABLE FOR CONSEQUENTIAL DAMAGES RESULTING FROM BREACH OF THIS WRITTEN WARRANTY OR ANY IMPLIED WARRANTY.

**DISCLAIMER**—Check-All® excludes from this warranty compressor discharge applications; valves mounted on the discharge of an elbow ("ell"); and failures due to corrosion, erosion, abrasion, cavitation, or other application-related failures and DISCLAIMS ANY EXPRESS OR IMPLIED WARRANTY OF FITNESS FOR A PARTICULAR PURPOSE. Further, it is the end user's responsibility to account for environmental influences such as traffic, wind, earthquake or other external loadings, decomposition of unstable fluids, simultaneous loadings or loadings due to fluid weight. There are no warranties that extend beyond the terms hereof and no one is authorized to assume for Check-All® any other liability in connection with the sale of Check-All® valves. This warranty supersedes all previous warranties.

## TERMS AND CONDITIONS OF SALE

**Terms:** Net 30 days with approved credit.

**Prices:** FOB FACTORY, West Des Moines, Iowa. All prices subject to change without notice. Any manufacturers' or sales tax or use tax payable on any transaction under any effective statutes will be added to the price of the goods.

**Shipment Date:** All statements of prospective shipping dates are estimates made in good faith. Maximum effort will be made to ship within the time estimated.

**Design:** We reserve the right to make design changes without notice.

**Returns:** All returns must be factory authorized within one year of purchase and are subject to restocking charges. Special valves and valves with permanent tags attached, are not returnable. Contact the factory for a Return Material Authorization form.

**Cancellations:** Firm orders which have been accepted are not subject to cancellation or changes except by written agreement to reimburse the company for costs incurred.

# *Service to Each Customer.*

Since its origin in 1958, Check-All Valve® Mfg. Co. has grown from an idea to a reality; from one type of valve to many styles; from a single use to multiple applications; from one material to many. Check-All Valve® Mfg. Co. has grown in all respects, yet one element has remained unchanged...service to each and every customer. Please feel free to put our personal and technical services to work on your particular project.

For Additional Details or Specifications contact Check-All Valve® Mfg. Co. or your Local Representative.

### TRADEMARKS USED IN THIS CATALOG:

- MONEL® ..... Special Metals Family of Companies
- INCONEL® ..... Special Metals Family of Companies
- VITON® ..... E.I. du Pont de Nemours and Company
- KALREZ® ..... E.I. du Pont de Nemours and Company
- TRI-CLAMP® ..... Alfa Laval Inc.
- Waukesha Cherry-Burrell® ..... SPX Corporation
- AFLAS® ..... AGC Chemicals Americas, Inc.
-  ..... Administered by 3-A SSI

# 2018

## INDUSTRIAL AND RESEARCH APPLICATION CATALOG

ISO 9001 CERTIFIED



